

おかげさまで45周年

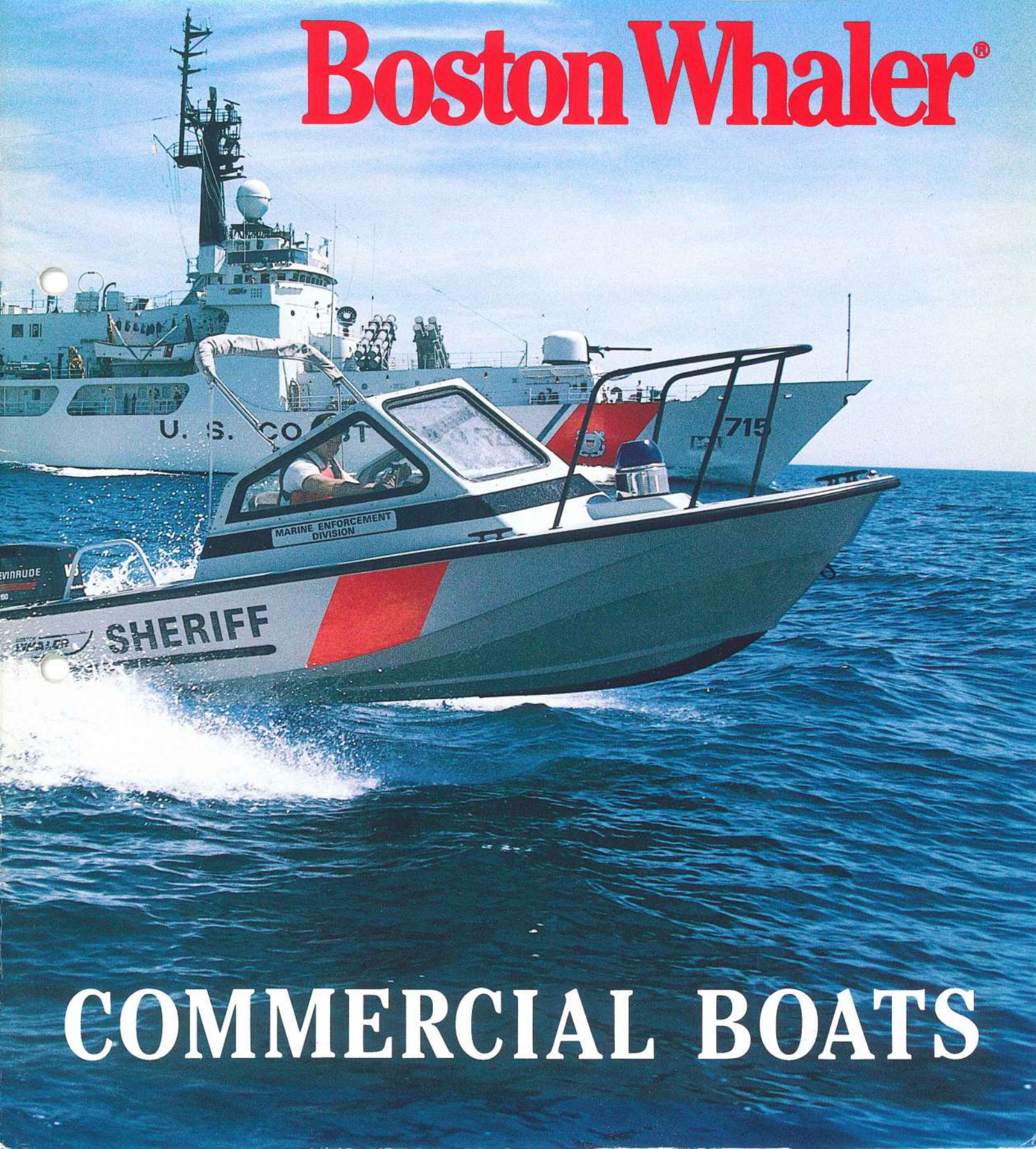

Boston Whaler®



COMMERCIAL BOATS

34 YEARS OF SERVICE

Boston Whaler has been building quality boats since 1958, and only in the last twelve years has it concentrated on servicing the government and commercial markets.

By making a good product better, and by listening to the demands of customers, we have been able to produce a product line second to none.

Today Whaler® Fire, Rescue and Police boats patrol the waterways of the world, used by discriminating agencies, who demand quality, safety and the inherent durability associated with the Boston Whaler name.

The products shown in this catalog are representative of the changes occurring in the marketplace; where speed, electronics surveillance and weather protection are becoming ever increasing design criteria.

Boston Whaler continues its design initiatives with products that will meet your expanding mission profiles now and into the 21st century.



19' Sentry



22' Raider®



22' Guardian (E.O.D.)



22' Raider®



27' Guardian

Boston Whaler® WORKBOAT LINE

How To Order

To outfit your Boston Whaler Workboat you may choose from a host of options listed in this Specification Book. If a desired piece of equipment is not listed or if you wish specific customization, contact your Boston Whaler Dealer or our Commercial Products Division for price and availability.

It should be noted in your selection process that Boston Whaler workboats exceed Coast Guard standards for flotation, and safety features. In addition, Whaler workboats are certified by NMMA insuring that your boat meets stringent standards for steering, electrical, fuel, flotation and safe powering.

Boston Whaler has a Limited Warranty which is unsurpassed in the commercial boat industry. For a copy of the Boston Whaler, Defiance Class or Combat Craft Limited Warranty (specify which) write the Commercial Products Division, Boston Whaler.



Boston Whaler Inc.
**COMMERCIAL PRODUCTS
DIVISION**
1149 Hingham Street
Rockland, MA 02370-0611
Telephone: (617) 871-1400
FAX (617) 878-4916

Table of Contents

UTILITY—13', 15' & 17'	2
GUARDIAN CLASS	4
GUARDIAN—17'	5
GUARDIAN—19'	6
GUARDIAN—22'	7
GUARDIAN—25'	8
GUARDIAN—27'	9
MILITARY & SECURITY BOATS	10
SENTRY—19', 22' & 25'	12
CHALLENGER—25'	14
CHALLENGER—27'	16
FRONTIER—25'	18
VIGILANT—27'	19
DEFIANCE—30'	20
DEFIANCE—36'	22
FIRE RESCUE BOATS	24
TRAILERS	26
TRAILER ACCESSORIES	27
COMMERCIAL ACCESSORIES	
Heavy Duty Hull Equipment	28
Hull Color & Lettering	30
Fuel Systems	31
Outboard Motor Equipment/Installation	31
Navigation & Safety	33
Seating	34
Law Enforcement Equipment	36
Weather Protection	36
Towing Equipment	37
Diving and Rescue Equipment	38
Electrical Accessories	39
Electronics	40
Fire Fighting Equipment	42
Commissioning Gear	43
Consoles & Options	44
Special Purpose Items	46
BOSTON WHALER LIMITED WARRANTY	47
DEFIANCE CLASS WARRANTY	47
CLIENT LIST	48

UTILITY 13', 15' & 17'

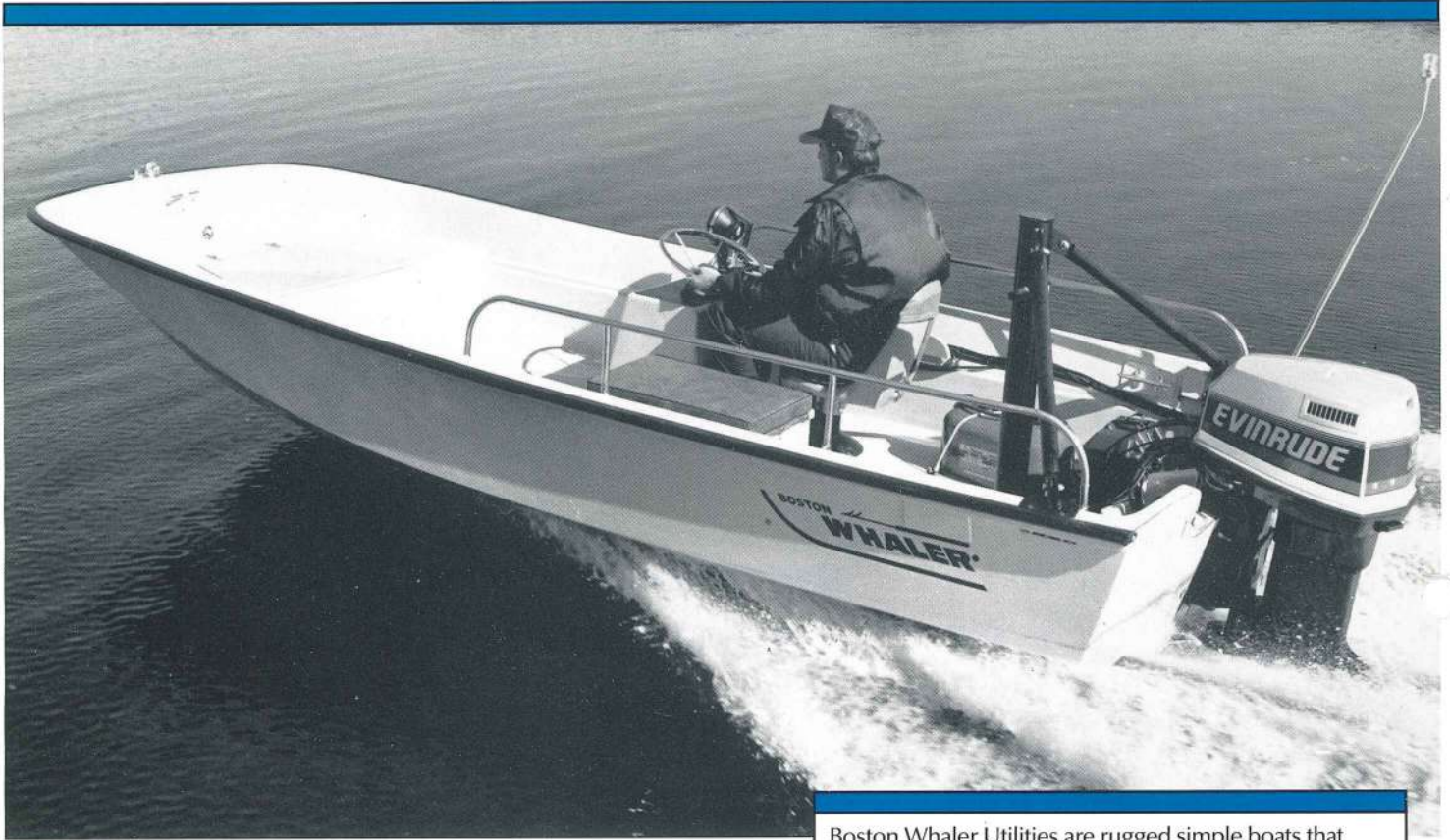

17' Utility w/swivel seat and deck utility box in place of standard thwart seat. Tow post provides an excellent method for towing oil booms.



13' Utility w/standard equipment



15' Utility shown with optional swivel seat (in lieu of thwart seat) and a 36" fiberglass deck utility box.



17' Utility w/standard equipment

Boston Whaler Utilities are rugged simple boats that fulfill a wide variety of marine applications. Whether sampling water, preserving wildlife or towing oil booms, they do the job well and with a degree of stability and safety uncommon in boats this size.

Because of their small size, light weight, low freeboard and shallow draft, these functional boats are easily trailered by small vehicles and are capable of being launched at remote sites.

Regardless of your choice, Boston Whaler Utilities are a dependable work platform and a sound investment.

STANDARD EQUIPMENT

- Unsinkable hull w/commercial fiberglass laminate
- Haze grey gelcoat hull and console
- Heavy duty rub rail
- Low profile fiberglass console with storage area
- Mechanical steering with stainless steel wheel
- Stainless steel side rails (15'-17')
- Bow storage locker w/fiberglass cover
- Bow eye with lifting eye
- Stern eyes with lifting eyes
- Battery box w/cast aluminum holder (17')
- Black identification and trim markings
- 10 year hull warranty

SPECIFICATIONS

	13'	15'	17'
LOA	13'4"	15'3"	16'7"
BEAM	5'5"	5'8"	6'2"
DRAFT ¹	6"	8"	9"
BOAT WGT.	410 lbs.	615 lbs.	1,000 lbs.
MAX. LOAD CAP.	1,200 lbs.	1,055 lbs.	1,415 lbs.
PERSONS CAP.	6	5	7
SWAMPED CAP. ²	1,600 lbs.	1,800 lbs.	2,000 lbs.
MAX. H.P.	40	70	100
MIN. H.P.	10	20	35
TRANSOM HGT.	20"	20"	20"

1. Draft with engines tilted clear of the water.

2. Total weight (persons, motor & gear) boat will support if filled with water.

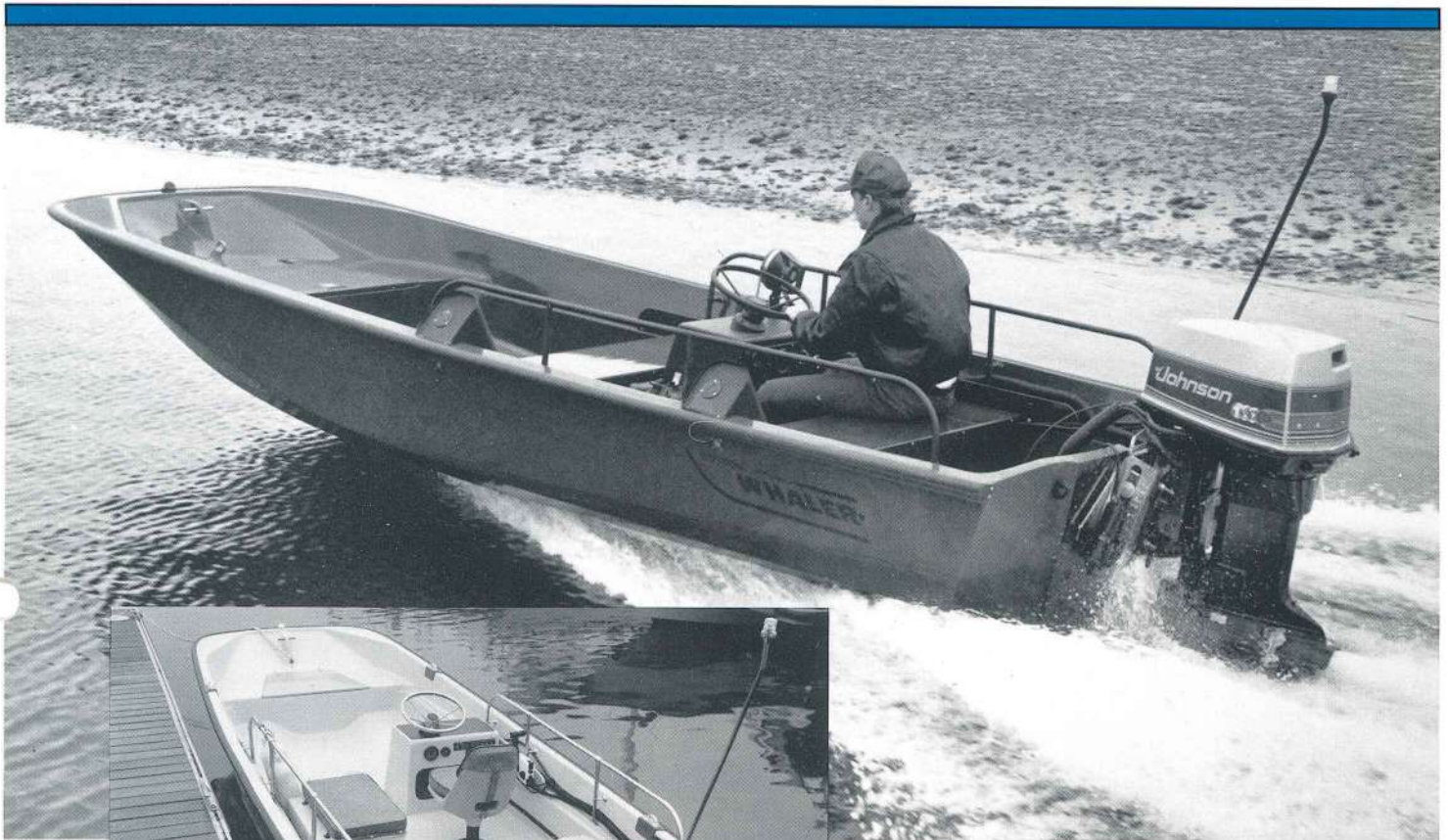

17' Utility w/70 H.P. outboard, swivel seat, and portside deck utility box.

For shallow water applications this 17' Utility has a raised transom, enabling the 100 horsepower JET to perform without cavitation or unnecessary drag. An extra thwart seat was installed to enhance passenger carrying ability and two 18 gallon fuel tanks under the seats improved range for operation in isolated areas.



14' Jetboat equipped with center mounted console, forward anchor locker, low profile bow and side rails, and H.D. rub rail. Power is 50 H.P. Yamaha.

14' JETBOAT SPECIFICATIONS

LOA	13'6"
BEAM	5'11"
DRAFT	6"
WEIGHT ¹	750 lbs.
POWER	Yamaha 50 H.P.

1. Displacement with engine.



The 13' Utility is easily converted into a "Fast Water Rescue Boat" with the addition of rescue rails, gunwale lifting eyes, special hull colors, and appropriate graphics.

GUARDIAN CLASS



This "Windshield "T" top option fits all Guardian consoles, and includes safety plate windows, small 6" high radio box, aluminum top for antenna mounting, canvas sun extension and rails.



Two "T" Tops are available. A medium duty unit shown below has a canvas top, hard points for antennas and lights, and a bolt-on fiberglass overhead radio pod. The "Heavy Duty" T-Top shown at left features the same tubular construction but includes a large welded overhead electronics box, aluminum plate roof, and extra heavy duty floor reinforcements. Front, side and rear drop curtains are available for both.



A "weather curtain set" shown attached to the windshield "T"-Top consists of P/S side curtains and rear drop curtain. Side curtains can be modified to fit other seating options such as leaning posts, etc.

Guardians are center console workboats featuring heavier fiberglass laminates than their recreational counterparts, larger deck hardware, a heavier rub rail, and haze grey gelcoat finish.

The position of the console adds to the versatility of these boats by permitting 360° access along the gunwales. To further enhance deck space aft, consoles may be positioned further forward as in the Dive Boat Package shown on page 5.

Guardians are unsinkable and unmatched.

STANDARD EQUIPMENT

- Unsinkable hull w/commercial fiberglass laminate
- Haze grey gelcoat hull and console
- Heavy duty rub rail
- Fiberglass console w/lockable door, windscreen and grab rail
- Hydraulic steering w/stainless steel wheel (mechanical on 17'-19')
- Heavy duty leaning post w/storage shelf and lockable doors (20'-27')
- Fiberglass bench seat on 17' & 19' models
- Navigation lights
- 10" Stern cleats & springline secured to 1/2" aluminum plates (19'-25')
- Bilge pumps fwd and aft w/auto/manual feature (17' & 19' has bilge pump aft only)
- Bow storage locker w/fiberglass cover
- Bow cleat
- Stainless steel bow and stern eyes, 5/8" on 19'-27'
- Fire extinguisher in recessed pocket
- Battery box w/cast aluminum holder
- Black identification and trim markings
- 10 year hull warranty
- 27' Guardian also has bow and stern rails, lockable quarter compartments, dual ram steering, second battery box, and (8) 12" deck cleats



GUARDIAN 17'



SPECIFICATIONS

	17'		
LOA	16'7"	MAX. H.P.	100
BEAM	6'2"	MIN. H.P.	35
DRAFT ¹	9"	TRANSOM HGT.	
BOAT WGT. ²	1,100 lbs.	Single O/B	20"
MAX. LOAD CAP. O/B	1,415 lbs.	FUEL CAP.—Standard	Portable tanks
PERSONS CAP.	7		
SWAMPED CAP. ³	2,000 lbs.		

1. Draft with engines tilted clear of the water.
2. Weight for outboard motors, Sterndrives 900 to 1500 lbs. heavier depending on power choice.
3. Total weight (persons, motor & gear boat will support if filled with water.

With the optional console front seat this 17' Guardian has three separate lockable, dry storage compartments.



Lockable bench seat has room for (2) 6 or 12 gallon fuel tanks plus storage shelf. Seat is also standard on 19' and optional on 20'-27' models.

By positioning the console on an aluminum bow deck extension, and adding rescue rails, stern rail, ladder yokes and H.D. flag mast, a compact "Dive Boat" is created.



Visibility through the safety plate windshield is excellent. The lockable deck utility box forward of the console provides additional dry storage. Performance with 70 H.P. varies between 32-34 MPH.

GUARDIAN 19'



Guardian 19' with standard bench seat and optional davit and torsional tow bar. Canvas system is furled on the bow deck.



19' Guardian w/34" hull cutout, H.D. diver's ladder, rubbing strakes and console siren shelf. Note this boat has the older G II console system.



19' Guardian with twin 50's performs very well, and provides outstanding fuel efficiency. The torsional tow bar, rubbing strakes, special Coast Guard colors, and hull slash were options that enhanced this boat's mission.

SPECIFICATIONS

	19'		
LOA	18'6"	MAX. H.P.	150
BEAM	7'2"	MIN. H.P.	75
DRAFT ¹	10"	TRANSOM HGT.	
BOAT WGT. ²	1,750 lbs.	Single O/B	25"
MAX. LOAD CAP. O/B	1,755 lbs.	Dual O/B	20"
PERSONS CAP.	7	FUEL CAP.—Standard	54 gal.
SWAMPED CAP. ³	3,000 lbs.		

1. Draft with engines tilted clear of the water.
2. Weight for outboard motors, Sterndrives 900 to 1500 lbs. heavier depending on power choice.
3. Total weight (persons, motor & gear boat will support if filled with water).

19' Guardian w/long deck upgrade

19' Guardian

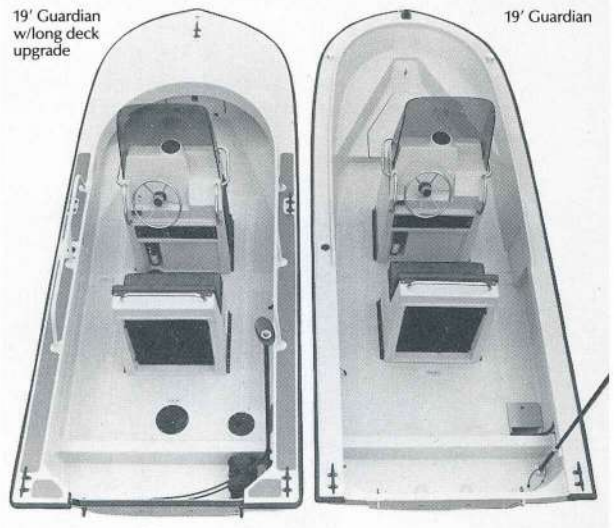

Comparisons between the standard Guardian and one with the long deck upgrade. Bench seat is standard on these models with numerous options available.

GUARDIAN 22'

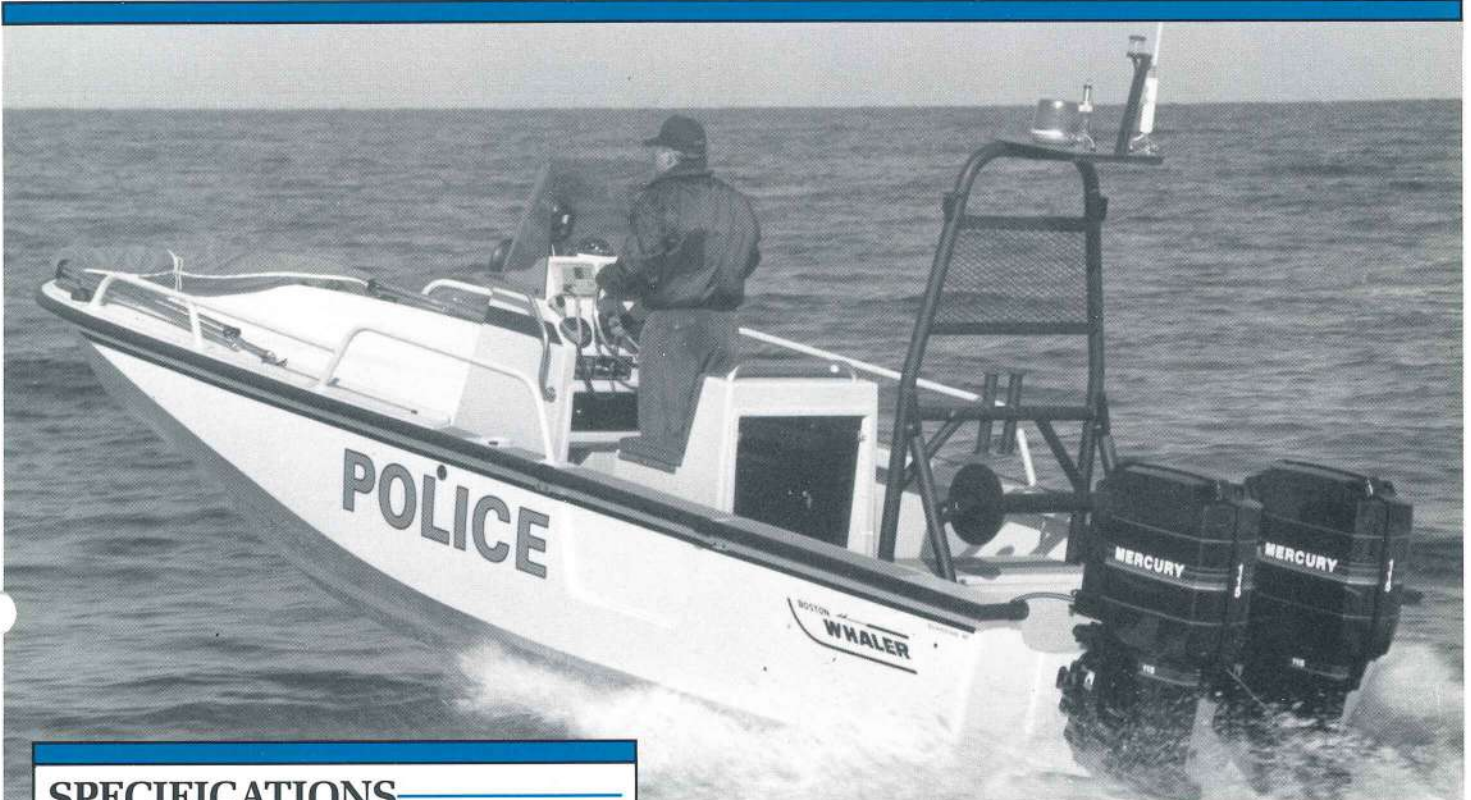

SPECIFICATIONS

	22'		
LOA	22'3"	MAX. H.P.	240
BEAM	7'5"	MIN. H.P.	85
DRAFT ¹	14"	TRANSOM HGT.	
BOAT WGT. ²	2,550 lbs.	Single O/B	25"
MAX. LOAD CAP. O/B	2,655 lbs.	Dual O/B	20"
PERSONS CAP.	11	FUEL CAP.—Standard	77 gal.
SWAMPED CAP. ³	5,000 lbs.	FUEL CAP.—Optional	127 gal.

1. Draft with engines tilted clear of the water.
2. Weight for outboard motors, Sterndrives 900 to 1500 lbs. heavier depending on power choice.
3. Total weight (persons, motor & gear boat will support if filled with water.

For patrol use, this Guardian was equipped with hi-low side rails, a tow post and leaning post/storage seat. A seat back was added for improved comfort when sitting on the leaning post. A sun top is shown in the furled position.

For rough water patrols, this 22' Guardian features a raised 30" transom, towing rail tower, and 34" dive door. A H.D. engine crash rail has yet to be fitted, which will protect the engines and prevent the tow line from fouling on them.



Used to clear mines in the Gulf, this special purpose Guardian had an aluminum console mounted forward, a long sun tent to keep divers cool, a 60" hull cutout, and stainless chafing plates in the dive door opening and transom corners. "Special Operations" lights are mounted on a reinforced mast which is easily removed for transport.

GUARDIAN 25'



This is a good profile of the heavy duty "T" top. With its aluminum plate roof and schedule 80 legs, the top is stiffened to support up to 150 lbs. Other options include the bow boarding platform, extended bow rail and bow spring line cleats. Extra dry storage is provided by the console deck utility box, a leaning post storage seat, and another 36" deck utility box aft.



25' Guardians may be equipped with gasoline or diesel I/O's. When installing this 210 Mercruiser I/O diesel, the console was shifted forward 24" for better weight trim. The medium duty "T" top has aluminum backing plates for (12") siren plus antenna bases.

SPECIFICATIONS

	25'		
LOA	24'7"	MAX. H.P.	300
BEAM	8'0"	MIN. H.P.	115
DRAFT ¹	16"	TRANSOM HGT.	
BOAT WGT. ²	3,575 lbs.	Single O/B	25"
MAX. LOAD CAP. O/B	3,035 lbs.	Dual O/B	20"
PERSONS CAP.	12	FUEL CAP.—Standard	140 gal.
SWAMPED CAP. ³	9,000 lbs.	FUEL CAP.—Optional	173 gal.

1. Draft with engines tilted clear of the water.
2. Weight for outboard motors, Sterndrives 900 to 1500 lbs. heavier depending on power choice.
3. Total weight (persons, motor & gear boat will support if filled with water.

Nimble, quick, stable and functional best describe this 25' Guardian. Options include hull cutout and special hull graphics. Note also the 30" transom option keeping engine powerheads well above water.



GUARDIAN 27'



SPECIFICATIONS

LOA	27'	MAX. H.P.	600
BEAM	10'0"	MIN. H.P.	300
DRAFT ¹	20"	TRANSOM HGT.	
BOAT WGT. ²	4,500 lbs.	Single O/B	N/A
MAX. LOAD CAP. O/B	4,000 lbs.	Dual O/B	25"
PERSONS CAP.	12	FUEL CAP.—Standard	170 gal.
SWAMPED CAP. ³	9,000 lbs.	FUEL CAP.—Optional	212 or 310 gal.

1. Draft with engines tilted clear of the water.
2. Weight for outboard motors.
3. Total weight (persons, motor & gear boat will support if filled with water.

27' Guardians can be powered with twin 150's up to twin 300's. Engines in the 175 to 225 range provide the best compromise between speed and fuel consumption.

The modified towing rail tower provides added crew safety in the event a tow line fails. A large fire pump is housed forward of the console.



With its 10' beam and full bow, the 27' is very stable and unusually seaworthy. Bow docking lights, Deep-V entry, and rubbing strakes are clearly visible.

MILITARY & SECURITY BOATS



When Roosevelt Roads Naval Station wanted to upgrade their security fleet, they moved up from 22' Raiders to the larger 27' Vigilant. With its enclosed pilot house, it gives crews both sun and rain protection and helps keep their electronics equipment drier. The gun arrangement places the light weight shoulder fired weapon forward in its plug in mount, while a heavy barrel .50 caliber is mounted in a heavy duty tripod aft.

With its 10' beam, this 27' Piranha has excellent stability and load carrying capabilities. The aluminum console has a fold down windshield for air craft deployment and the extended sun tent helps keep the crew relatively cool. Quarter mounts are reinforced for either 7.62 (shown) or .50 caliber heavy barrel machine guns. Boston Whaler's heavy duty tri-axle trailer makes movement of this 8,000 lb. package easy with the proper tow vehicle.



This 22' Guardian, when equipped with a pair of 100 H.P. outboards, siren, strobe, and forward plug in gun mount, becomes a cost effective and simple drug enforcement patrol boat that is air deployable.

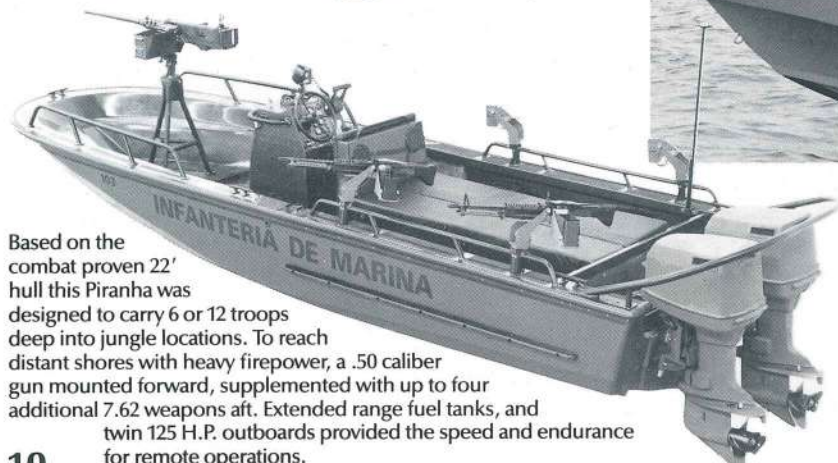

Based on the combat proven 22' hull this Piranha was designed to carry 6 or 12 troops deep into jungle locations. To reach distant shores with heavy firepower, a .50 caliber gun mounted forward, supplemented with up to four additional 7.62 weapons aft. Extended range fuel tanks, and twin 125 H.P. outboards provided the speed and endurance for remote operations.



A number of these 22' Raiders provided port security during the Desert Shield/Storm operation. Firepower, electronic surveillance and 40 knot speeds were assets the Coast Guard relied upon to keep the ports open. Pairs of these compact patrol boats were flown to the Gulf in C-130 aircraft.



This shows the excellent field of fire available when the "plug in mount" is installed forward on the Vigilant 27'. Other security equipment includes a radar, strobe lights, and communications, all factory installed.



19' Rigid Raiding Craft with a carrying capacity of 10 troops, speeds well over 30 knots, and 54 gallons of fuel, this small assault craft can be launched from mother ships for over the horizon deployment. Keels, gunwales, and lifting hardware all have been beefed up for tough military service. Over 120 units are currently in service worldwide.

SENTRY CLASS 19', 22' & 25'

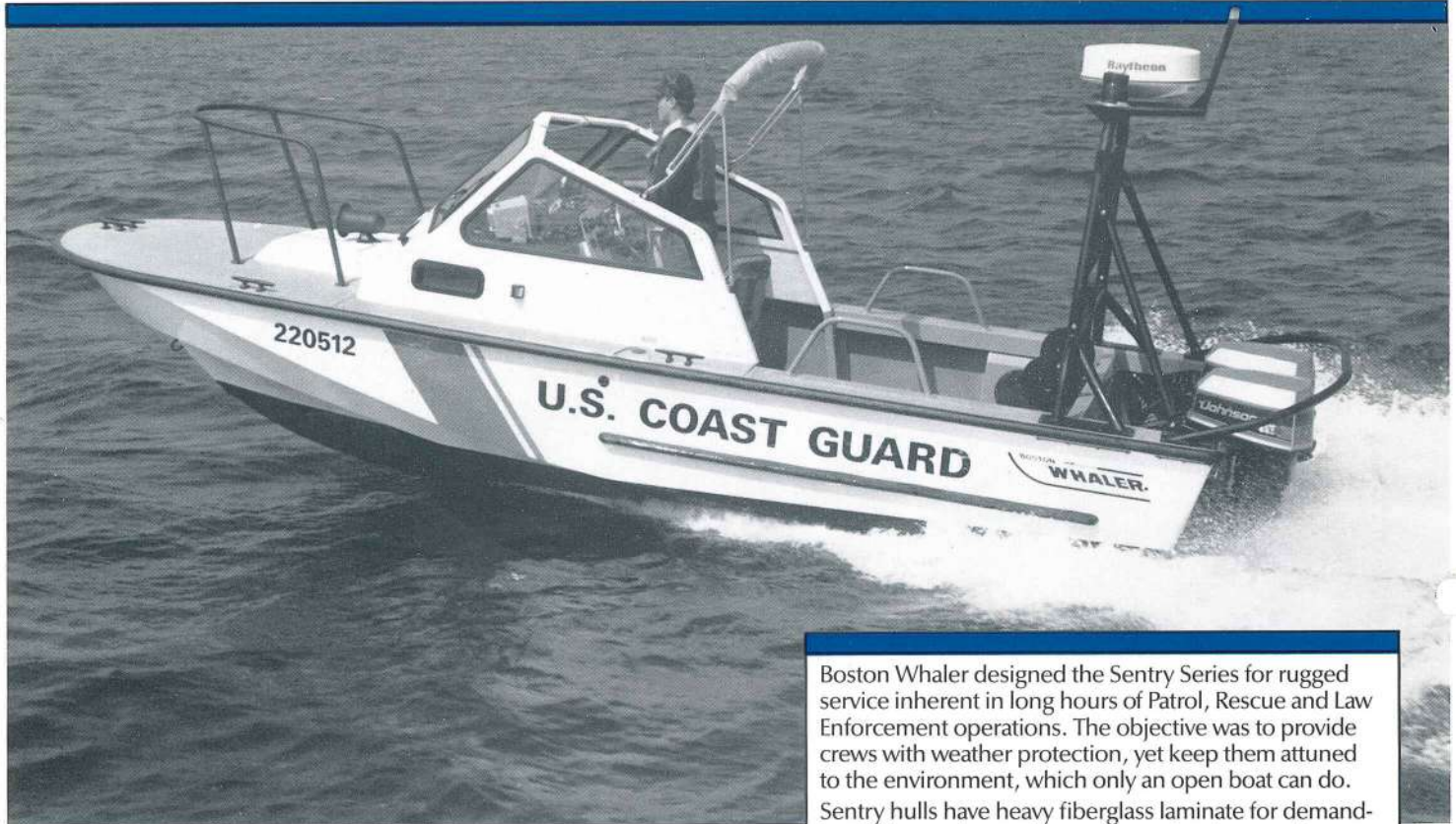

22' SENTRY with Coast Guard Graphics package, torsional towing rail tower, crash rail and a streamlined siren forward on the bussel.

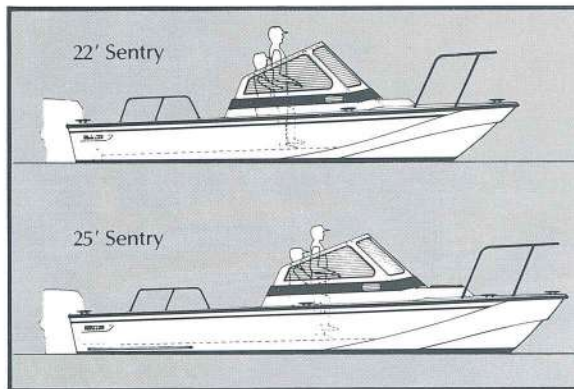

The 19', 22' & 25' Sentries have fiberglass desks and windshields.



Speed with this single 225 varies from 40 to 43 M.P.H. depending on loads, trim and prop selection. A 6" sheer stripe enhances the hull, while the optional stern seat provides added comfort for more passengers. Other options include a bow hatch, flying top set and trim tabs.

Boston Whaler designed the SENTRY Series for rugged service inherent in long hours of Patrol, Rescue and Law Enforcement operations. The objective was to provide crews with weather protection, yet keep them attuned to the environment, which only an open boat can do. SENTRY hulls have heavy fiberglass laminate for demanding high speed pursuits or unintentional groundings. They have been kept clean and functional for easy maintenance, good looks and to provide the buyer with years of dependable service.

STANDARD EQUIPMENT

- Unsinkable hull w/commercial fiberglass laminate
- Haze grey gelcoat hull
- Heavy duty rub rail
- Fiberglass bow deck w/integral windshield and lower cuddy cabin
- Fiberglass side decks
- Pilot and side rails
- Lockable cabin door
- Pilot and companion seats
- Cabin portlights w/screens
- Hydraulic steerer w/stainless steel wheel
- Commercial switch panel w/dimmer
- Navigation lights
- Cuddy dome light
- 10" cleats (5) bow, springline, stern (12" on 27')
- Stainless steel bow and stern eyes
- Bilge pumps fwd and aft w/auto/manual feature (aft only on 19')
- Fire extinguisher
- Battery box w/cast aluminum holder
- Cabin accent stripe
- Black identification and trim markings
- 10 year hull warranty
- 27' SENTRY also has stern quarter rails, lockable quarter deck storage compartments, bow deck hatch, dual ram steering, 19 switch commercial panel and electric horn.

SPECIFICATIONS

	19'	22'	25'
LOA	18'6"	22'3"	24'7"
BEAM	7'2"	7'5"	8'0"
DRAFT ¹	10"	14"	16"
BOAT WGT. O/B	1,750 lbs.	2,850 lbs.	3,875 lbs.
MAX. LOAD CAP. O/B	1,755 lbs.	2,655 lbs.	4,000 lbs.
PERSON CAP.	7	9	12
SWAMPED CAP. ²	3,000 lbs.	4,000 lbs.	8,000 lbs.
MAX. H.P. O/B ³	150	240	300
MIN. H.P. O/B	75	100	150
TRANSOM HGT. Single O/B	25"	25"	25"
TRANSOM HGT. Dual O/B	20"	20"	20"
FUEL CAP.—Standard	54 gal.	77 gal.	140 gal.
—Optional		127 gal.	173 gal.

1. Draft may vary slightly depending on load and engine size.
2. Total weight (persons, motor and gear) boat will support if filled with water.
3. Higher horsepower available only for law enforcement applications.



This 19' Sentry performs extremely well when matched to Evinrude's 150. Cornering, acceleration, and maneuvering can be accomplished without cavitation. Hull slash, rubbing strakes and 12" strobe/siren are several visible options.



Sentry canvas provides added weather protection. Headroom is 6'3". Plexiglass windshield is removable for ventilation, or top only can be flown for sun protection.

All Sentries can be equipped with a flying top set which consists of: top with storage boot, removable windshield (connects top to boats windshield), side curtains, and rear drop curtain.



CHALLENGER 25'

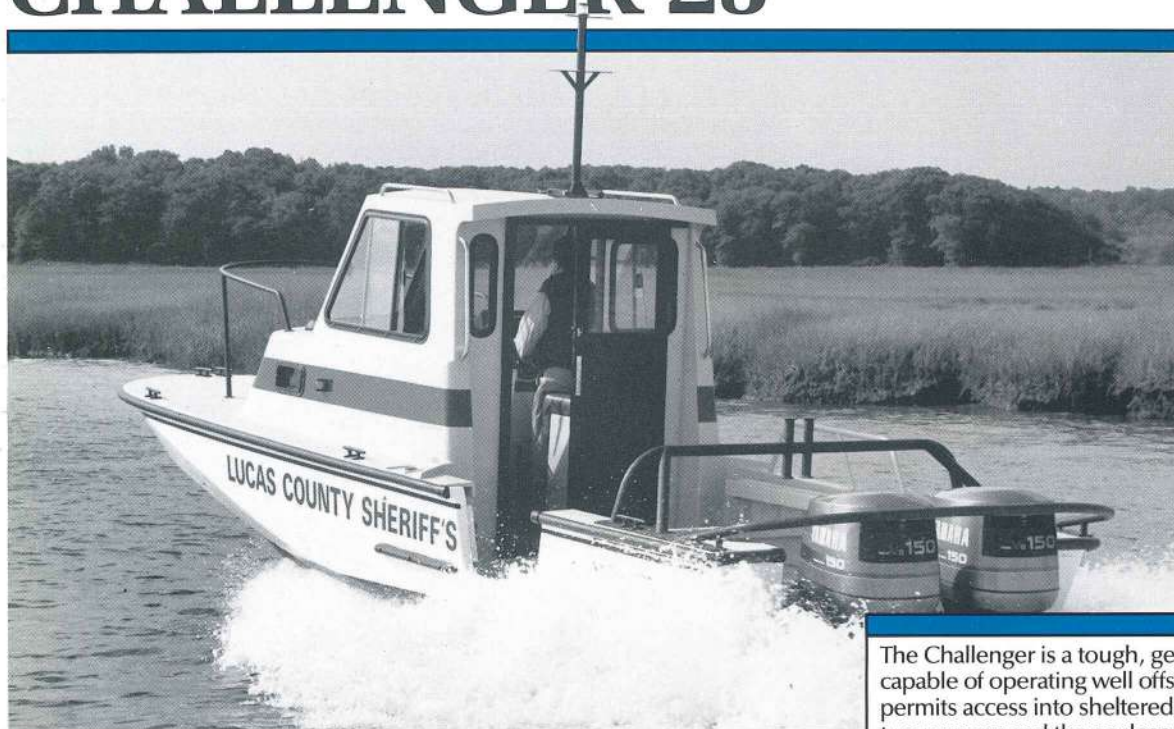

Although a rear drop curtain is standard with the pilot house many agencies have chosen the bulkhead option with lockable door. For summer operation this bulkhead may be unbolted and stored ashore.

The Challenger is a tough, general purpose workboat, capable of operating well offshore, yet its shallow draft permits access into sheltered bays and rivers. It can sleep two persons and the enclosed pilot house protects the crew from the extremes of wind and rain.

Toughness is what the Challenger is all about. The hull is specially molded for commercial applications and it provides the user with "peace of mind" inherent in 8000 pounds of reserve buoyancy.

The Challenger—a rugged, unsinkable workboat.

STANDARD EQUIPMENT—

- Unsinkable hull w/commercial fiberglass laminate
- Haze grey gelcoat
- Heavy duty rub rail
- Pilot house w/lower cuddy cabin
- Pilot rail—black
- Lockable cuddy door
- Pilot seat
- Fixed forward windows
- Sliding side windows
- Cuddy 12" x 12" hatch on bustle
- Cuddy portlights w/screens (2)
- Rails—cabin roof & pilot house
- Hydraulic steerer w/stainless steel wheel
- Windshield wipers
- Defroster fans
- Hydraulic trim tabs
- 14 function switch panel w/LED "on" lights and dimmer
- Overhead mounting panel
- Folding light mast
- Navigator lights
- Cuddy light
- Pilot house dome light (red)
- Rear drop curtain w/zippered door (bulkhead w/door optional)
- 10" cleats (8) bow, bow springline, springline and stern
- Stainless steel bow and stern eyes
- Bilge pump fwd and aft w/auto/manual feature
- Fire extinguisher
- Battery box w/cast aluminum holder
- Cabin accent stripe
- Black identification and trim markings
- 10 year hull warranty

SPECIFICATIONS

	25'	
LOA	24'7"	FUEL CAP.—Optional
BEAM	8'0"	173 gal.
DRAFT ¹	16"	COCKPIT FLOOR
BOAT WGT. O/B	4,100 lbs.	DIMENSIONS O/B
MAX. LOAD CAP. O/B	3,035 lbs.	6'6" x 10'
PERSON CAP.	12	CABIN DIMENSIONS
SWAMPED CAP. ²	8,000 lbs.	Width
MAX. H.P. O/B ³	300	Length
MIN. H.P. O/B	150	Headroom
TRANSOM HGT. Single O/B	25"	Bunk Length
TRANSOM HGT. Dual O/B	20"	72"
FUEL CAP.—Standard	140 gal.	PILOT HOUSE DIMENSIONS
		Width
		Length
		Headroom

1. Draft may vary slightly depending on load and engine size.
2. Total weight (persons, motor & gear) boat will support if filled with water.
3. Higher horsepower available only for law enforcement applications.



Equipped with a Volvo 200 H.P. Diesel this Challenger has speeds between 28–32 knots depending on weight or the duo prop option. Mercruiser, gas or diesel I/O's are also available.



Pusher knees provide a very rugged option for pushing barges or nosing into vertical breakwaters.



With special storage lockers, this 25' Challenger was arranged to transport life rafts with capacity for 108 persons. In addition, its rescue door, and the boats 12 person capacity, combined with high speed and shallow draft make it well suited as an airport rescue boat.

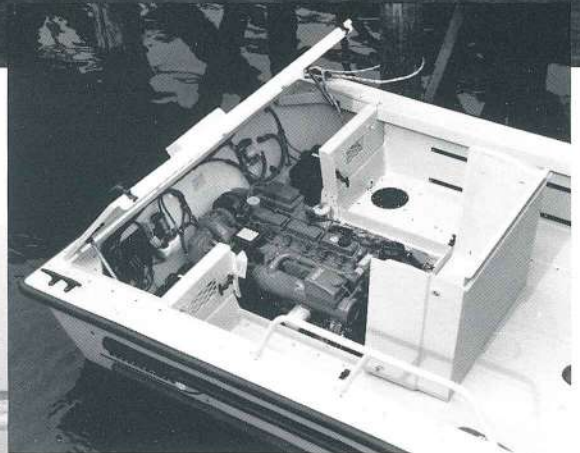

The large stern hatch and folding engine cover provide excellent engine serviceability.



Visibility over the bow, wide flat decks, and inboard rails make this Challenger well suited for patrol work.

CHALLENGER 27'



Wide side decks, ample hand rails, excellent visibility, and a deep cockpit are just a few of many reasons why the Challenger 27' is respected as a Patrol Officers patrol boat.

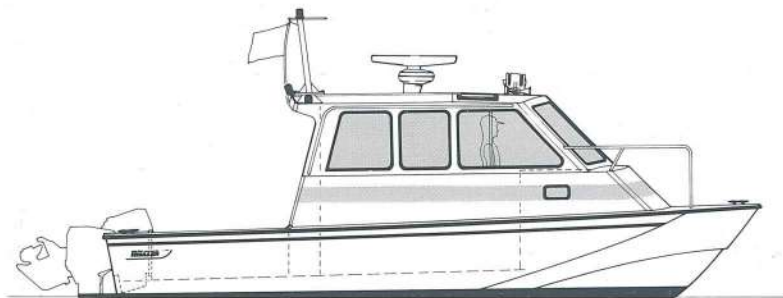
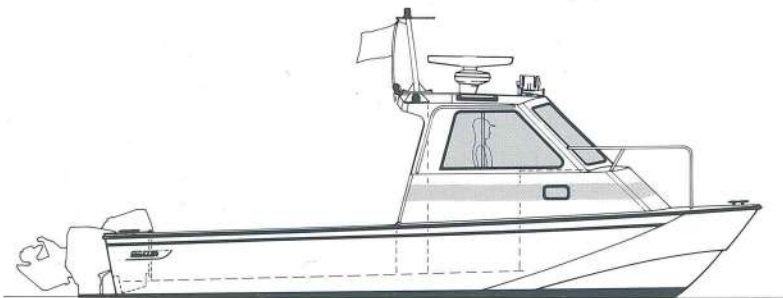

Two optional versions of the fiberglass Challenger are available. In the short version there is room forward for two bunks with portable marine head between. This configuration is intended to maximize stern cockpit length, which varies between 11' 6" & 10' depending on drive systems.

The extended version features a 6' long Pilot House. The same size cuddy as the short version, and a cockpit that measures 5' 9" long by 8' 6" wide. This configuration is ideal when people, cargo, or large sophisticated electronics such as side scanning sonars have to be installed in a dry environment.

Please consult factory for pricing, availability, and your interior requirements.

STANDARD EQUIPMENT

- Unsinkable hull w/commercial fiberglass laminate
- Haze grey gelcoat
- Heavy duty rub rail
- Fiberglass pilot house w/lower cuddy cabin
- Fiberglass bow and side decks
- Pilot rail—black
- Stern quarter rails
- Lockable aft quarter deck storage compartments (2)
- Lockable cuddy door
- Pilot and companion seats
- Fixed forward windows
- Sliding side windows
- Cabin 16" x 16" vent hatches (2) on roof
- Cuddy air vents (2) on bustle
- Cuddy 20" x 20" vent hatch on bustle
- Cuddy portlights w/screens (2)
- Rails—cabin side and stern quarters
- Windshield wipers
- Defroster fans
- Hydraulic trim tabs
- Hydraulic steerer w/dual ram and stainless steel wheel
- 13 function switch panel w/LED "on" lights and dimmer
- Overhead electronics compartment
- Folding light mast
- Navigator lights
- Electric horn
- Cuddy lights (2)
- Pilot house dome light (red)
- Rear drop curtain w/zippered door
- 12" cleats (8) bow, bow springline, springline and stern
- Stainless steel bow and stern eyes
- Bilge pump fwd and aft w/auto/manual feature
- Fire extinguishers (2)
- Battery boxes (2) w/cast aluminum holders
- Cabin accent stripe
- Black identification and trim markings
- 10 year hull warranty

SPECIFICATIONS

LOA	26'7"	FUEL CAP.—	
BEAM	10'0"	Option #1	212 gal.
DRAFT ¹	21"	Option #2	310 gal.
BOAT WGT. O/B	6,200 lbs.	COCKPIT FLOOR	
MAX. LOAD CAP. O/B	4,000 lbs.	DIMENSIONS O/B	8' x 6'
PERSON CAP.	12	CABIN DIMENSIONS	
SWAMPED CAP. ²	9,000 lbs.	Width	82"
MAX. H.P. O/B ³	600	Length	108"
MIN. H.P. O/B	300	Headroom	70"
TRANSOM HGT.		Bunk Length	72"
Single O/B	N/A	PILOT HOUSE DIMENSIONS	
TRANSOM HGT.		Width	79"
Dual O/B	25"	Length	57"
FUEL CAP.—Standard	170 gal.	Headroom	68"

1. Draft may vary slightly depending on load and engine size.
2. Total weight (persons, motor & gear) boat will support if filled with water.
3. Higher horsepower available only for law enforcement applications.

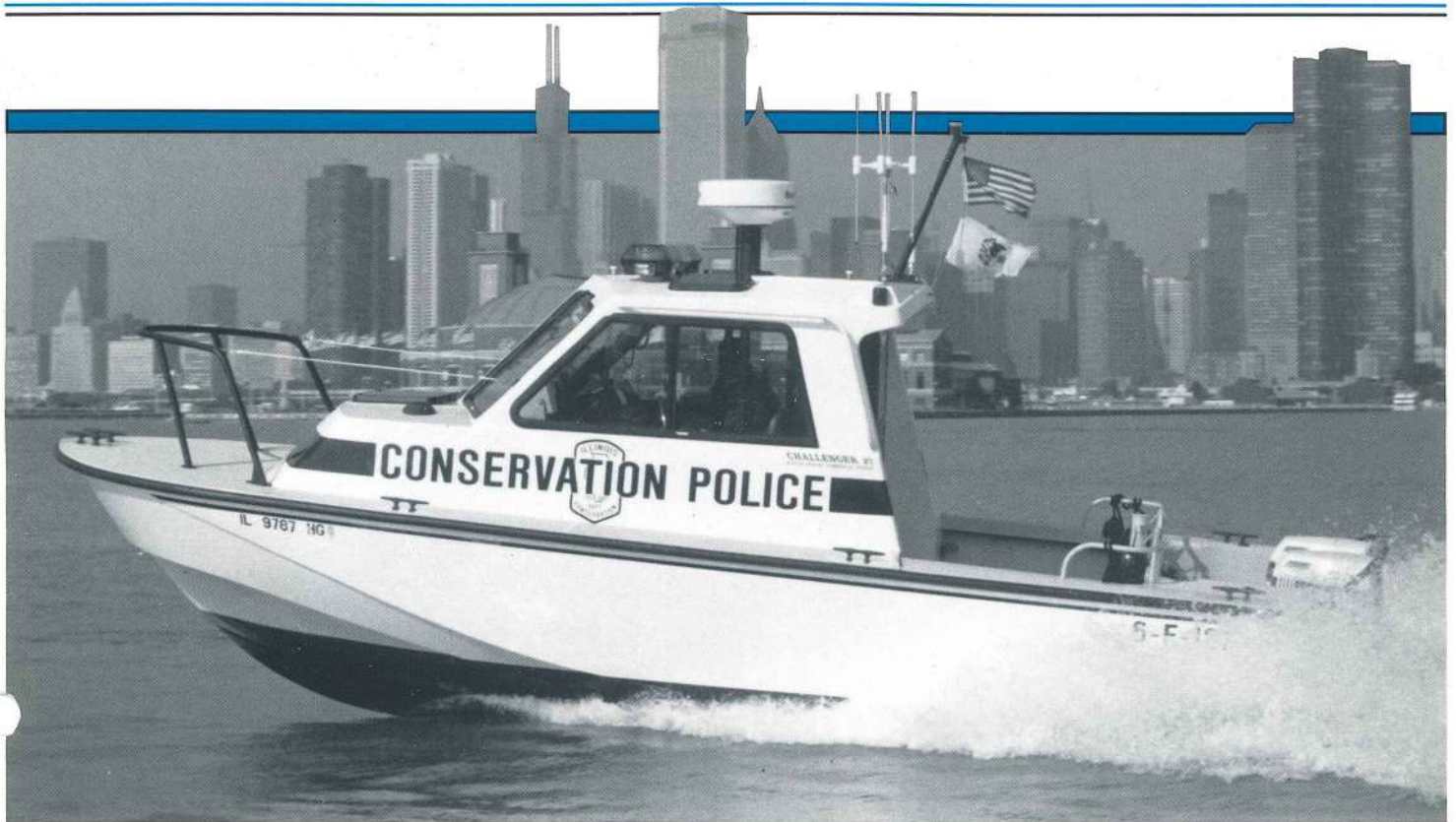

The new Challenger 27' has larger windows for excellent look down visibility. Note how seated crew members have excellent forward visibility and the ease in which they can open and communicate through the sliding side windows.

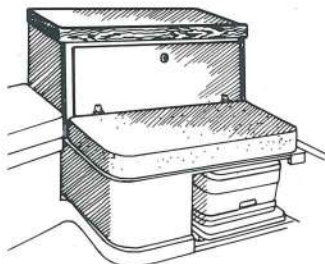

27' Challenger vanity unit features lift up cushion over Porta Potti and storage locker behind.



27' Challenger galley unit mounts on port side and features a large chart drawer and four storage drawers, top surface for chart work, etc.



The standard rear drop curtain was completely removed in this photo to give a clear view of the helm station. Note the high pedestal seats which are standard. Options shown include, dual spotlights, radar, flood lights, strobe lights, Coast Guard graphics package and tow post.

FRONTIER 25'



The roof overhang of the Frontier 25' provides good shade for occupants and forms a drip edge for the side windows. Look down visibility is excellent on this model.

Frontier 25's feature a fold down seat for stand-up driving.



With a 34" cutout and the radial arm davit, this harbormaster can easily retrieve small buoys. For towing assignments, the tow tower and crash rail aft works well.

The Frontier is a good inshore work and patrol boat. Its large cockpit and lockable cabin make it ideally suited for harbormasters, research firms, pollution control and environmental monitoring.

Power is typically twin outboards in the 90 to 150 H.P. range, although inboard/outboard gas or diesels are available.

The lockable cabin door provides comfortable room for two persons and optional cushions and head are available for extended work assignments.

Because of its forward steering station, the Frontier is not recommended for violent offshore search and rescue missions. The Challenger or Sentry are more suited and were designed for these extremes.

The Frontier is easily trailered, making it an ideal mobile work platform.

STANDARD EQUIPMENT

- Unsinkable hull w/commercial fiberglass laminate
- Haze grey gelcoat hull and cabin
- Heavy duty rub rail
- Fiberglass pilot house
- Fiberglass gunnels
- Black bow rail
- Folding helmsman seat
- Fixed front windows
- Sliding side windows
- Sliding lockable cabin door
- Rails—outer cabin and interior pilot house
- Heavy duty cockpit side rails
- Hydraulic steerer w/stainless steel wheel
- Windshield wipers
- Defroster fans
- Hydraulic trim tabs
- 14 function switch panel w/LED "on" lights and dimmer
- Overhead mounting panel
- Folding light mast
- Cuddy light
- Pilot house dome light (red)
- 10" cleats (8) bow, bow springline, springline and stern
- Stainless steel bow and stern eyes
- Bilge pump fwd and aft w/auto/manual feature
- Battery box w/cast aluminum holder
- Fire extinguisher
- Cabin accent stripe
- Black identification and trim markings
- 10 year hull warranty

SPECIFICATIONS

	25'	
LOA	24'7"	FUEL CAP.—Standard 140 gal.
BEAM	8'0"	FUEL CAP.—Optional 173 gal.
DRAFT ¹	16"	COCKPIT DIMENSIONS
WGT. O/B	3,900 lbs.	@ FLOOR 7'0" x 9'4"
MAX. LOAD CAP.	3,000 lbs.	PILOT HOUSE DIMENSIONS
PERSON CAP.	12	Headroom 6'4"
SWAMPED CAP. ²	8,000 lbs.	Width @ floor 6'0"
MAX. H.P.	300	Length @ floor 33" & 40"
MIN. H.P.	150	BUNK LENGTH 6'10"
TRANSOM HGT.		BUNK HEADROOM 38"
Single O/B	25"	CABIN HEADROOM 58"
TRANSOM HGT.		
Dual O/B	20"	

1. Draft may vary slightly depending on load and engine size.
2. Total weight (persons, motor & gear) boat will support if filled with water.

VIGILANT 27'

When equipped with the optional sun roof, this Vigilant is more suitable for operation where sun and high temperatures are a concern.



This powerful 27' patrol boat is the collective design efforts of several key people responsible for the security of waterfront facilities. It incorporates state-of-the-art thinking relative to anti-terrorist interdiction, fisheries law enforcement, and harborside surveillance. Special attention has been paid to operator visibility both day and night, boarding officer requirements, and comfortable crew seating.

The center cabin provides 360° access to all decks, crew protection from the elements, lockable dry electronic installations, and the amenities of an enclosed head and storage lockers.

STANDARD EQUIPMENT

- Unsinkable hull w/commercial fiberglass laminate
- Haze grey gelcoat hull
- Heavy duty rub rail
- Fiberglass pilot house w/lower cuddy cabin
- Low pattern bow/side rails
- Stern quarter decks
- Lockable aft quarter deck storage compartments (2)
- Lockable sliding cuddy door
- Pilot and companion seats w/slides
- Sliding side windows
- Cuddy air vents (2)
- Cuddy portlights w/screens (2)
- Rails—outer cabin and interior pilot house
- Hydraulic steerer w/dual ram and stainless steel wheel
- Windshield wipers
- Defroster fans
- Hydraulic trim tabs
- 14 function switch panel w/LED "on" lights and dimmer
- Electronics distribution panel
- Overhead electronics compartment
- Folding light mast
- Navigation lights
- Electric horn
- Cuddy lights (2)
- Pilot house dome light (red)
- Rear drop curtain w/zippered door (bulkhead w/door optional)
- 12" cleats (8) bow, bow springline, springline and stern
- Stainless steel bow and stern eyes
- Bilge pump fwd and aft w/auto/manual feature
- Fire extinguishers (2)
- Battery boxes (2) w/cast aluminum holders
- Cabin accent stripe
- Black identification and trim markings
- 10 year hull warranty

SPECIFICATIONS

LOA	26'7"	PILOT HOUSE OVERALL DIMENSIONS	
BEAM	10'0"	Width	68"
DRAFT O/B ¹	19"	Length	126"
BOAT WGT. ²	5,000 lbs.	Height above floor	83"
MAX. LOAD	4,000 lbs.	PILOT HOUSE INTERIOR DIMENSIONS	
SWAMPED CAP. ³	9,000 lbs.	Width	64"
MAX. H.P. O/B	600	Length	44-52"
MIN. H.P. O/B	300	Headroom	78"
FUEL CAP.—Standard	173 gal.	CUDDY DIMENSIONS	
FUEL CAP.—		Width	62"
Option #1	212 gal.	Length	65"
FUEL CAP.—		Headroom	66"
Option #2	310 gal.		

1. Draft with engines tilted clear of water.
2. Weight is for outboard motors. Sterndrives 900 to 1500 lbs. heavier depending on power choice.
3. Total weight (persons, motor & gear) boat will support if filled with water.

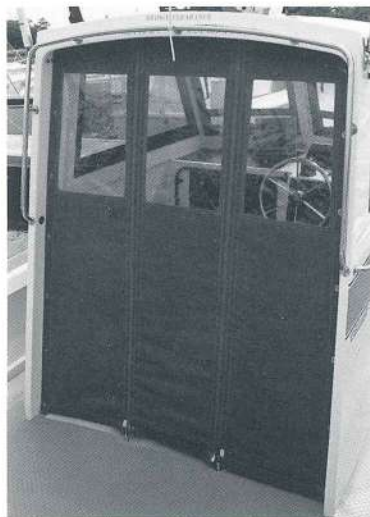

With a walkaround cabin, tow post and large deck hardware this Vigilant can perform port security operations or search and rescue missions. With a pair of V-6 175's speed is well over 30 knots, and range is over 160 miles with the standard 170 gallon tank.

The drop curtain is standard, however an optional bulkhead improves the all weather capability of this Vigilant.

DEFIANCE Aluminum 30' Outboard



Large walkaround cabin, wide gunwales, abundant hand rails and smooth deep V-hull are just a few of the many features that make the Defiance 30' such a good offshore patrol boat.



30' Defiance center cabin has room for four seats plus cuddy and interior accompaniments.



Dive door and ladder enhance the 30's rescue and recovery capabilities.

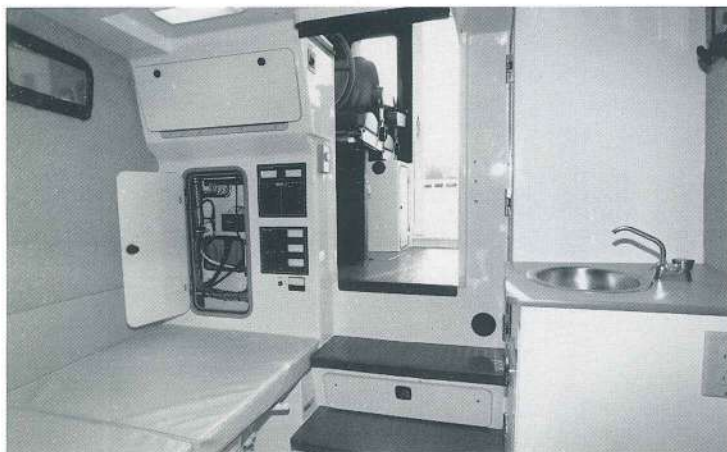

This big, stable 30-footer can comfortably operate in rough bays or negotiate ocean seas over 10'. Sea trials have taken place in breaking surf, temperatures down to 0°; ice to 2" and snow reducing visibility to ½ mile. In spite of these adverse conditions the boat handled exceptionally well. Cabin temperatures remained in the 60's and the hull remained tight and dry. The Defiance 30's seakeeping virtues are the results of a good design combined with quality workmanship, attention to detail, and careful placement of weight and continued testing. All of this produced a patrol boat that performs and looks better than the competition. Test drive a Defiance and you'll see, feel and experience the difference.

SPECIFICATIONS

	I/B	O/B
LOA	30'-0"	31'3"
BEAM	11'3"	11'3"
DRAFT	3'-4"	2'-0"
DEADRISE AFT	21°	21°
DEADRISE FWD	50°	50°
DISPLACEMENT	12,500 lbs.	8,000 lbs.

SCANTLINGS

BOTTOM PLATE	¼"	¼"
SIDE PLATE	⅜"	⅜" or ¼"
BULKHEADS	⅜"	⅜"
LONGITUDINALS	¼" x 3"	¼" x 3"
CENTER VERTICAL KEEL	⅜" x 3"	⅜" x 3"
SHEER GUARD	⅜" x 3"	⅜" x 3"
CHINE	¼" x 6"	¼" x 6"
TRANSOM CURVE	⅜"	¼"
TRANSOM FLAT	⅜"	¼"
BULL NOSE	¼"	¼"

Optional interiors are available. This configuration includes 9' and 6' bunks, hanging locker, galley area with sink, pressure water and chart drawer. Head is under starboard bunk aft.

DEFIANCE Aluminum 30' Inboard



30' Defiance inboard engine room is designed for gas or diesel engines up to 600 or more horsepower. Twin Crusaders produced speeds of 32 knots during sea trials.



Dive doors either in hull side or transom make servicing aids to navigation or diver recovery much easier and safer.



Optional galley unit includes 110V/12 Volt refrigerator, two burner stove and sink with water tank.



Optional V-Berths with folding table, and 110 volt cabin heater.



In addition to special hull graphics and markings, this diesel powered 30' had ice reinforcing, heat & air conditioning, 5kw generator, and a host of other equipment making it suitable as a year-round patrol boat. Speed with twin Cummins 300 H.P. diesels was in excess of 32 knots.

DEFIANCE Aluminum 36' Inboards



At 32 knots, note how clean this Defiance runs. Plan speeds start at 10 knots and trim angle remains constant at 3.5° to 4° through the speed range.



The generous 13' beam provides unmatched stability at rest and in unsettled sea conditions.



Light bar, extended mast, hydraulic capstan and dive door net rollers were several options that enhanced this patrol boat's functionality.

The Defiance 36' is a fast, rugged versatile patrol boat with quality consistent with Boston Whaler's reputation as a leader in the workboat field.

From the keel up, the Defiance had the boarding officer in mind. Good slow speed maneuverability, wide side decks, abundant hand rails, engine serviceability and operator visibility were just a few of the many features taken into account during design studies and final construction.

The hull incorporates the latest developments in Deep-V technology for aluminum construction. It has the characteristics that are necessary to give comfort and control in all sea conditions, plus generous beam combined with wider chines for excellent stability at rest.

SPECIFICATIONS

LOA	36'-0"	DEADRISE AFT	21°
BEAM	13'-0"	DEADRISE FWD	50°
DRAFT	3'-6"	DISPLACEMENT	19,000 to 23,000 lbs.

SCANTLINGS

BOTTOM PLATE AFT	5/16"	CENTER VERTICAL KEEL	1/2" x 6"
BOTTOM PLATE FWD	1/4"	SHEER GUARD	5/16" x 3"
SIDE PLATE	3/16"	CHINE	5/16" x 6"
BULKHEADS	3/16"	TRANSOM CURVE	1/4"
LONGITUDINALS	1/4" x 4"	BULL NOSE	1/4"

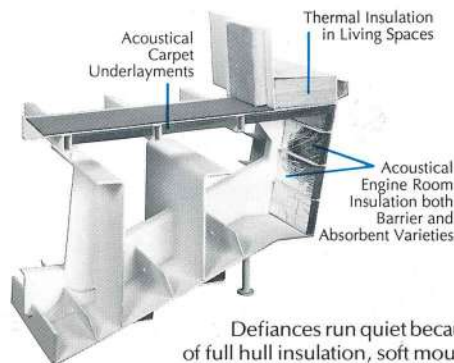

Defiances run quiet because of full hull insulation, soft mounts and balanced props and shafts.

Driver ergonomics and visibility are excellent. Overhead radio box has room for a wide variety of electronics. Large wipers, fans, roof hatches, hand rails, gauge pod and two H.D. seats are all standard on the Defiance.



Custom cabinets provide storage for charts, manuals, and guns in the lower locker.

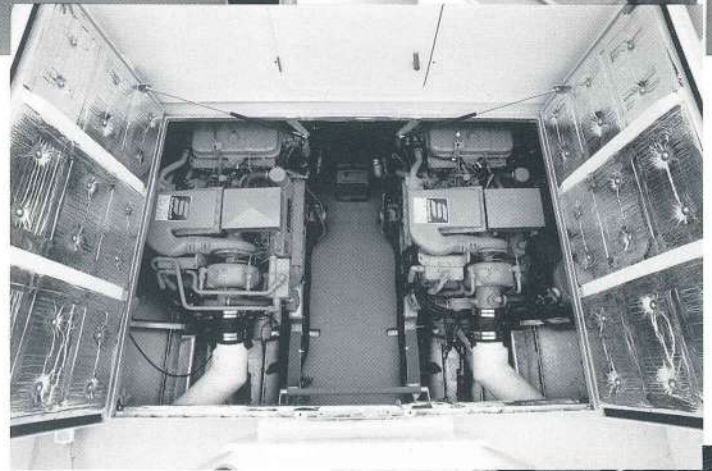

Caterpillar 3208TA's easily fit into the Defiance's large engine room. 5Kw generator mounts between shaft logs aft.

The microwave oven, refrigerator, and sink with hot and cold pressure water are visible in this photo.

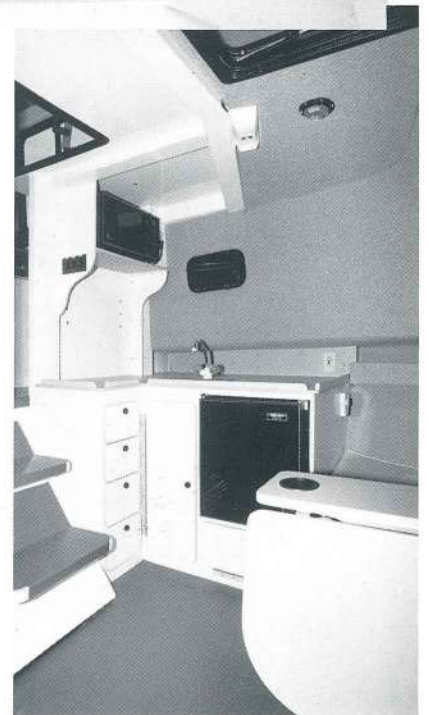

CONSTRUCTION FEATURES

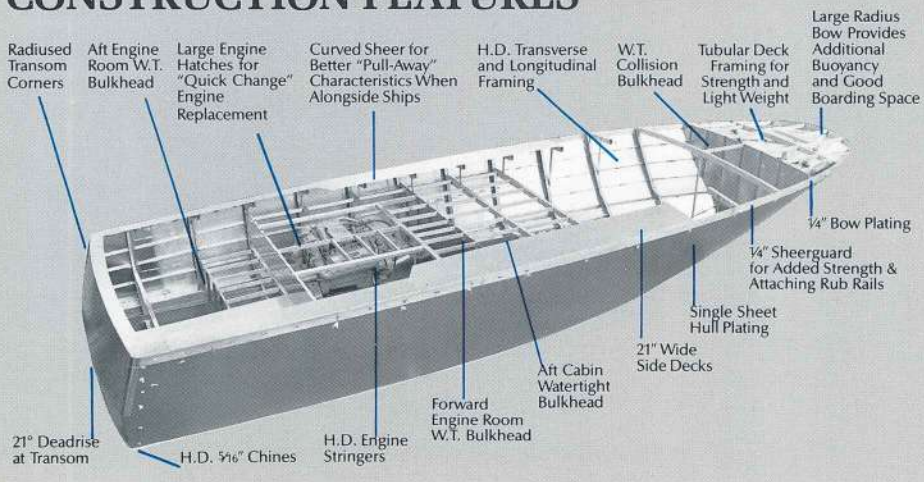

BOSTON WHALER

Boston Whaler has been building Fire/Rescue boats since 1981. During that period designs have improved in the areas of pumping capacities, rescue equipment and vessel size. Today, departments can select from a wide variety of boats to meet their operational and budgetary requirements.

Safety, quality and durability are features that have earned Whaler the respect of Fire/Rescue Departments around the world. Unsinkable hulls, 10 year structural warranties and functional designs are just a few of the reasons these boats are purchased.

Whaler's large fire pump engines are fully marinized with water cooled fuel pumps, structural drip pans, six engine/pump mounts, oversized exhausts, and high capacity ventilation blowers. All pump engines comply with NMMA and Coast Guard standards for safety.

Pump systems are very efficient and corrosion resistant. Intakes are 6" fiberglass pipes that provide a smooth flow to the Darley/Champion Bronze Pump. For below waterline pump installations, a 6" butterfly valve is used, simplifying the task of pump repairs or removal.

Large 4" discharge manifolds insure minimum pressure drops as flow is directed into (3) 2½" bronze ball valves or through a 4" line to a remote monitor.



Bronze monitor and 1000 GPM nozzle. Smaller nozzles available with 18HP and 75HP systems.



75HP marine pump system. Highest power to weight ratio on the market.



18HP portable marine pump system.



17' Utility with 18HP pump and starboard side console



27' Guardian with 75HP fire pump, double rubbing strakes and custom graphics package.



25' Guardian with 18 HP pump, weather protection "T" top and 34" rescue door.



25' Frontier equipped with 75HP fire pump. Note: tow rail tower with crash screen protecting crew from recoil of failed tow-line or fitting.



25' Frontier fireboat with full electronics and emergency lighting for night and low visibility fire/rescue operations.

FIRE RESCUE BOATS



Pump capacities have been determined by continuous testing and impeller refinements at the pump manufacturer's plant where every pump/engine combination is tested prior to delivery to Boston Whaler.

After installation, every Fire Boat is sea trialed under full power conditions to verify performance, pressure test the pump system and to check the boats handling characteristics with monitors positioned in all directions.

25' Pilot House model w/75HP pump system. Note: excellent walkaround feature for rescue and boarding operations.

Fire Boats become more functional rescue boats with such options as diver recovery doors, hull mounted rescue rails, towing systems, high intensity lighting, stretcher racks and other equipment that is the collective design ideas of Boston Whaler and our customers.

The overriding goal of this team is the saving of lives and property.



130HP marine pump system. Engine governor and relief valve are standard on this and larger systems.

225HP marine pump system. Available on 27' models and up. Capable of supplying up to three "master streams".

BOSTON WHALER FIRE PUMPS

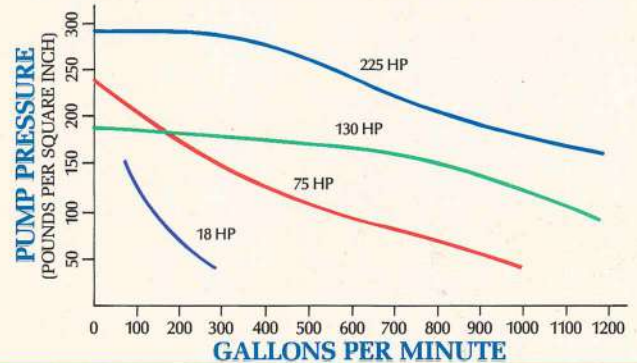

Note: 1. Curves represent capacities as installed, operating at full throttle and taking into account piping losses.
2. The 130HP and 225HP models show flattened curves at the low volume end, due to the effect of the engine overspeed governor.



25' Guardian with 75HP pump system, custom console and towing rail tower.



17' Guardian equipped with 18HP fire pump mounted under the bench seat.



25' Guardian with deck mounted pump system, dive door and torsional tow bar.



22' Guardian with special color scheme and portable pump with custom aluminum enclosure.



27' Challenger with 225 H.P. pump which feeds two 1 1/2" deck lines, two 2 1/2" deck lines and 3" bow monitor.

TRAILERS



13' Galvanized

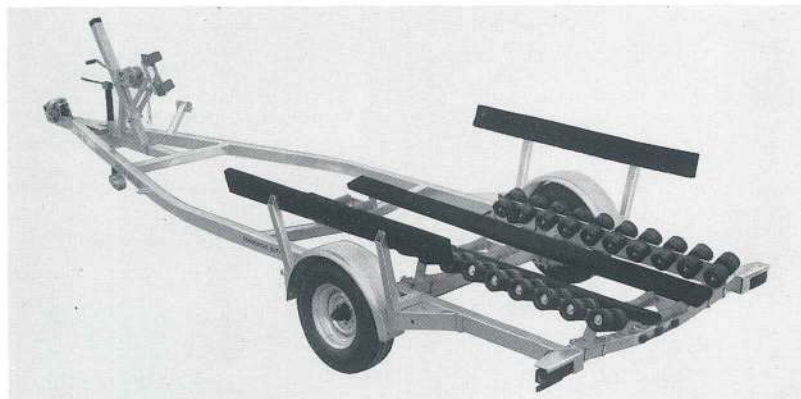

19' Galvanized

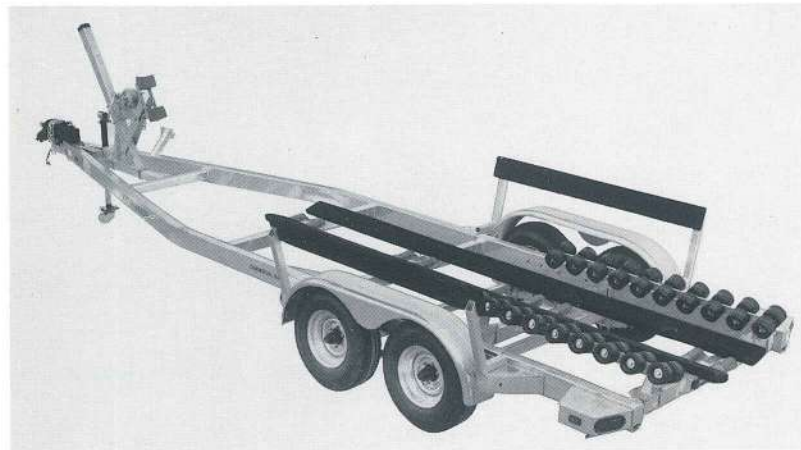

22' Galvanized



27' Galvanized



Commercial service places unusual demands on boat trailers. In addition to the corrosive effect of salt water, trailers are subjected to overloading, operator abuse, rough off-road travel, limited maintenance and often thousands of miles of use.

To provide a product that can withstand this treatment, Boston Whaler has designed a trailer for heavy duty applications, utilizing the best industry equipment available, combined with our years of trailering experience. The end result is a trailer that is both unique and uncommonly rugged.

Most important, however, is the fact that each trailer is designed and fitted for each Boston Whaler hull size. This insures proper hull support, balance and safety both on the highway and when launching or retrieving boats.

STANDARD EQUIPMENT

- Dual safety chains w/hooks
- Hydraulic surge brakes (18' & up)
- Galvanized axles
- Galvanized wheel rims
- Stoltz keel rollers
- 6" Keel guide bunks
- Roller train (18' & up)
- Float on side guides (except 27')
- Heavy wall tubular chassis and cross members
- Front and rear fender step pads
- Movable undercarriage.
- Waterproof tail lights
- Heavy duty winch
- Caster jack
- Welded on spare tire carrier
- Galvanized finish

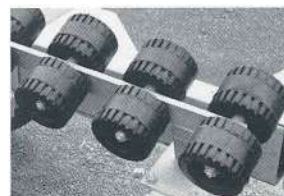

Exclusive fixed roller train permits easy drive-on/drive-off operations

Welded-on spare tire carrier



TRAILERS & TRAILER ACCESSORIES

Whaler trailers are designed for each specific hull length and shape. Particular attention has been given to support along the keel and ease in launching and retrieval. These drive on trailers are available in painted or galvanized finish and each offers many standard features

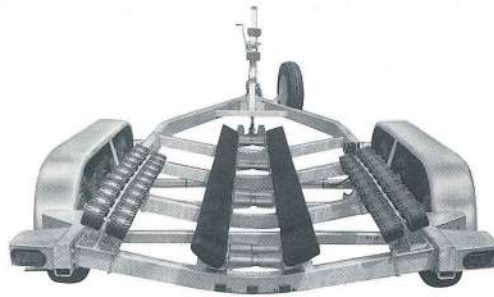

normally listed as options on other brands. Polyurethane keel rollers, caster jacks, waterproof lights and Bearing Buddy® to name a few. For more information or a separate trailer catalog please contact the factory.

TRAILER SPECIFICATIONS

BOAT SIZE MODEL PART NO.	13' WT13S G5-9400-13	15' WT15S G5-9400-15	17' WT17S G5-9400-17	19' WT19S G5-9400-19	20' WT20S G5-9400-20	22' WT22S G5-9400-22	25' WT25S G5-9400-25	27' WT27S G5-9400-27
Load Capacity	1,500 lbs.	1,500 lbs.	2,400 lbs.	3,200 lbs.	4,500 lbs.	8,000 lbs.	8,000 lbs.	12,000 lbs.
G.V.W. Rating	2,000 lbs.	2,000 lbs.	3,000 lbs.	4,000 lbs.	6,000 lbs.	10,000 lbs.	10,000 lbs.	15,000 lbs.
Trailer Wt.	500 lbs.	500 lbs.	600 lbs.	800 lbs.	1,500 lbs.	2,000 lbs.	2,000 lbs.	3,000 lbs.
Tire Size	B78/13	B78/13	8/14.5F	8/14.5F	8/14.5F	8/14.5F	8/14.5F	8/14.5F
Number of Axles	One	One	One	One	Two	Two	Two	Three
Ball Size	2"	2"	2"	2"	2 5/16"	2 5/16"	2 5/16"	2 5/16"
Chassis Size	2" x 3"	2" x 3"	2" x 4"	3" x 4"	3" x 5"	3" x 6"	3" x 6"	3" x 6"
Brakes 1 Axle	N/A	N/A	OPT	STD	STD	STD	STD	STD (2)
Brakes 2nd Axle	N/A	N/A	N/A	N/A	OPT	OPT	OPT	OPT (3rd)
Overall Length	14' 5"	16' 5"	18' 5"	20' 5"	22' 5"	24' 5"	27' 5"	29' 5"
Overall Width	80"	80"	83"	89"	89"	89"	96"	96"
Keel Rollers (10")	2	2	3	6	8	8	8	8
Keel Guide Bunks	N/A	N/A	N/A	2	2	2	2	2
Float on Guides	STD	STD	STD	STD	STD	STD	STD	N/A
Caster Jack	STD	STD	STD	STD	STD	STD	STD	STD
Caster Capacity	500 lbs.	500 lbs.	500 lbs.	2,000 lbs.	2,000 lbs.	2,000 lbs.	2,000 lbs.	2,000 lbs.
Spare Tire Carrier	STD	STD	STD	STD	STD	STD	STD	STD
Bearing Protector	STD	STD	STD	STD	STD	STD	STD	STD
Waterproof Lights	STD	STD	STD	STD	STD	STD	STD	STD
Winch Capacity	1,200 lbs.	1,200 lbs.	1,700 lbs.	2,800 lbs.	3,200 lbs.	3,200 lbs.	3,200 lbs.	3,200 lbs.
Winch Line	Rope	Rope	Rope	Wire	Wire	Wire	Wire	Wire

TRAILER OPTIONS

Description	Part No.	13'	15'	17'	19'	20'	22'	25'	27'
Pintle Ring Hitch	G5-9400-57	N/A	N/A	N/A	N/A	OPT	OPT	OPT	OPT
Brakes	G5-9400-49	N/A	N/A	OPT	STD	STD	STD	STD	STD
Brakes 2nd Axle	G5-9400-54	N/A	N/A	N/A	N/A	OPT	OPT	OPT	STD
Brakes 3rd Axle	G5-9400-54	N/A	N/A	N/A	N/A	N/A	N/A	N/A	OPT
Spare Tire w/Rim 15'	G5-9400-50	OPT	OPT	N/A	N/A	N/A	N/A	N/A	N/A
Spare Tire w/Rim 17-27'	G5-9400-53	N/A	N/A	OPT	OPT	OPT	OPT	OPT	OPT
Pneumatic Caster Wheel	G5-9400-60	N/A	N/A	N/A	OPT	OPT	OPT	OPT	OPT



Pneumatic caster wheels provide high flotation support, and won't damage aircraft loading docks



Pintle hitch options include bolt-on 2 3/16" ball assembly (except for 27')



Heavy duty 14.5 tires on 17'-27' trailers with heavy duty 6 lug galvanized rims and Buddy Bearings

COMMERCIAL ACCESSORIES

HEAVY DUTY HULL EQUIPMENT

STERN SPLASHWELL BULKHEAD G5-9560-00

Bulkhead for outboard powered models 20'-25'. Designed to prevent following seas from splashing into cockpit. Large freeing ports assist in bailing boat in event of swamping. Matches hull color.

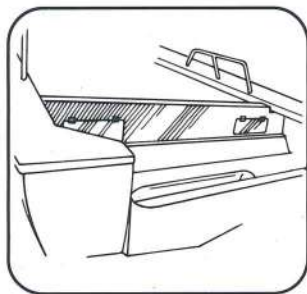

HELICOPTER LIFTING EYES G5-9141-00

1/2" stainless steel lifting plates with lift hole of 1 1/4". Each plate is through-bolted using 5 stainless bolts. Hull area substantially reinforced with extra glass and high tensile fibers. Aluminum and wood inserts provide pull out security. Highly recommended for shipboard applications or where personnel are in boat when lifted. Factory installed only. Set of 4 only.



10" DECK CLEATS G5-9006-00

Heavy duty 10" cleats secured with four stainless machine bolts into 1/2" thick aluminum plates glassed within the hull. Specify location. Factory installed only. Set of 2.

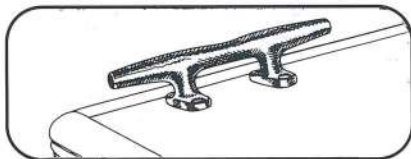

HEAVY DUTY RUBBING STRAKES

G5-9035-02 - One Per Side

G5-9035-04 - Two Per Side

Large 3" rubber "D" sections bolted through hull. Flexible enough to absorb impact. Protects hull when lying alongside ships or low piers. Rubbing strakes (one per side) are required when ordering lashing rails. 13'-27' hulls.



LASHING RAILS G5-9039-00

Rails through-bolted to hull to provide secure method of tying down loose deck cargo. Requires installation of rubbing strakes. Set of 2.

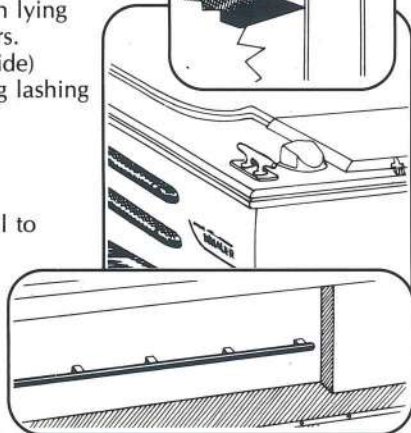

HEAVY DUTY STAINLESS STEEL CUTWATER G5-9234-00

Heavy 1/8" 316 grade stainless plate is formed around stem. Approximately 8" wide (4" either side of keel) and 6' long from hull spray deflector aft. Designed for impact and chafe resistance. Hull has additional laminate for extra strength. For 17'-27' models. Factory installed only.



HEAVY DUTY STAINLESS STEEL BOW EYE REINFORCEMENT G5-9122-00

1/8" stainless steel is formed around stem in the bow eye location. Hull area is heavily reinforced with fiberglass and aluminum. Designed for hard use applications where boats are towed at high speed. Used when resistance to pull out and loosening of bow eye has to be assured. Factory installed only on 17'-27' hulls.

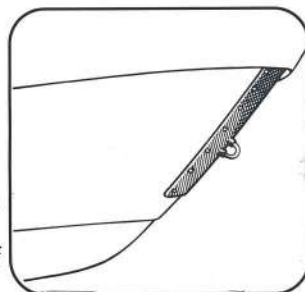

SELF-BAILING SCUPPER PACKAGE G5-9123-00

Includes two fiberglass 1 1/2" tubes extending through aft bulkhead into splashwell. Permits rain or washdown water to drain directly overboard. May not work on certain heavily loaded models or I/O's. Suitable for 19'-25' models. Consult factory before ordering.

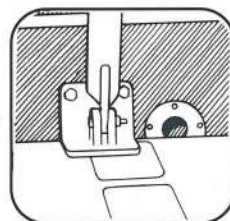

H.D. ALUMINUM GUNWALE UPGRADE G5-9000-00

Sturdy 3/16" aluminum gunwales replace standard fiberglass units on 19'-25' center console models. Recommended for abusive service such as diving or salvage. Painted to match hull color. Non-skid walking surface.

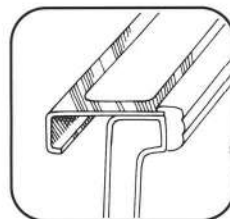

LOW PATTERN BOW RAIL G5-9062-00

Heavy duty welded construction using 1 1/4" O.D. pipe. Provides security when working in bow area. Length varies per model. For 19' and larger Guardian and Pilot House models.

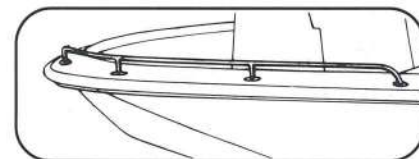

HEAVY DUTY HULL EQUIPMENT cont.

HI-LOW SIDE/BOW RAIL G5-9520-00

Heavy duty 1 1/4" O.D. pipe provides good grip and strength. All welded construction assures stiffness so important in this type of rail system. Side rail portion elevated to provide security amidships while forward section is low to not restrict work over the side. Recommended for rough water applications on Guardians 19'-25'.

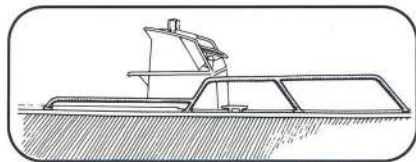

HIGH PATTERN SIDE RAILS G5-9232-00

Welded construction using 1 1/4" O.D. pipe for good grip and strength. Installed to provide added security in cockpit area. Standard on some models.

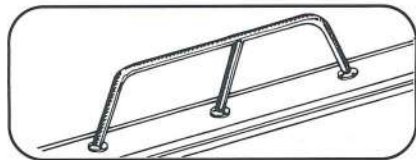

GUNWALE LIFTING EYES G5-9130-00

13'-15'-17' models. For lifting and rescue work where static lines have to be rapidly secured to hull. Factory installed only because hulls are reinforced locally to accept eyes. Set of 4.

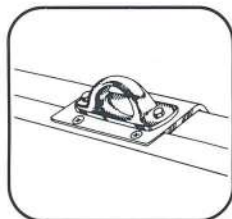

8" INBOARD CLEATS 13'-15'-17' MODELS G5-9142-00

Rugged 8" cleats secured to hull interior using 4 stainless steel bolts. Mounted approximately 5" down from the gunwale, they provide a H.D. tie-up option. Large compression plates on the inside and outside of hull prevent hull damage. Set of 2.

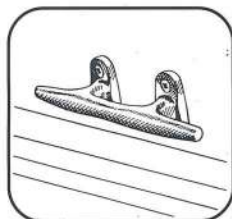

WATERTIGHT DECK HATCHES

These H.D. hatches are used for access into areas below the cockpit floor on 22', 25' & 27' boats. They provide watertight access into large storage cavities. Natural aluminum finish. Please consult factory before ordering.

- G5-9788-00 15" I.D.
- G5-9789-00 20" I.D.
- G5-9790-00 15" X 24" I.D.
- G5-9799-00 12" X 18" I.D.*

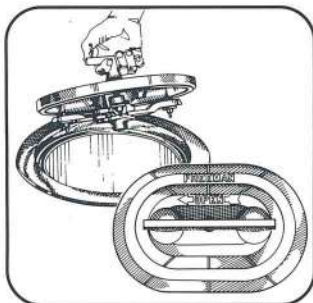

*One is standard on Guardian 22', 25' & 27'.

TRANSOM REINFORCEMENT PACKAGE G5-9120-00

For installations where factory recommended horsepower is exceeded or unusually abusive service expected such as Combat Craft. Package includes multiple layers of fiberglass over transom. Available for certified law enforcement, fire/rescue or military applications only. 19'-25' models. Factory installed only.

TRANSOM EXTENSION G5-9121-00

Increases transom height on 22'-25' to accept twin 25" (extra long shaft) outboard motors. Factory installed only.

TRANSOM CORNER CHAFE PLATES G5-9118-00.

316 grade stainless steel plate is carefully wrapped around transom corners down to waterline. Prevents hull from being chafed away on unprotected docks or floats. Extra internal fiberglass thickness is required. Factory installed only. Available on 17' - 27's.

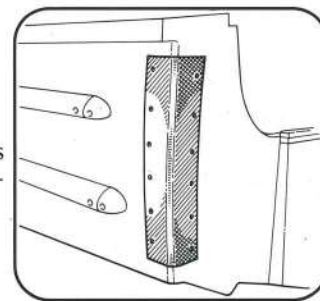

EXTENDED BOW PLATFORM W/HATCH & REINFORCEMENTS G5-9013-00

This rugged aluminum bow platform can be added to 22' and 25' Guardians as a working deck (shown) or to mount a console forward as shown on page 7. Deck surface is 10" below gunwale level, has non-skid surface and water tight hatch for access to storage below. Hull fastening inserts require this to be factory installed.

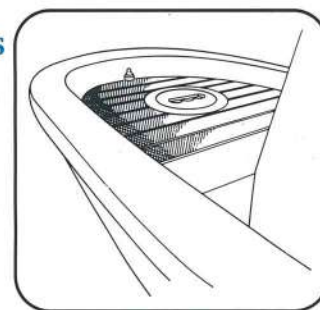

HEAVY DUTY BOW FLOOR PLATE G5-9014-00

For 22', & 25' Guardians. Consists of heavy duty plate mounted at bow area aft of anchor locker. Because of special hull inserts, deck is available factory installed only. Note: This option includes extended tunnel for cables and controls. Anchor locker remains accessible.

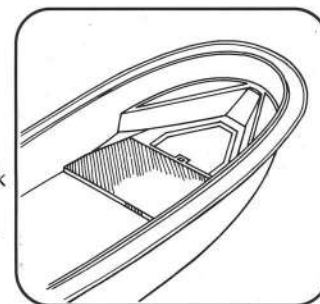

FLOOR TIE DOWNS G5-9040-00

These light duty tie downs are fitted flush into the floors of all models except 13's. Measures approximately 2" x 3" and have lift up handles to secure items on the floor. Because floor has to be routed and reglassed this option is factory installed only. Priced per item. Send sketch or call factory to describe locations desired.

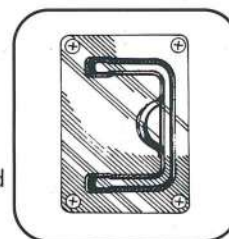

TRANSOM CAP G5-9119-00

A stainless steel formed plate that covers the top of the transom to prevent damage to the fiberglass from repeated engine changes. Powder coated flat black.

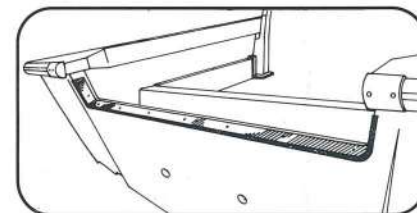

HEAVY DUTY HULL EQUIPMENT cont.

BOW BOARDING PLATFORM W/RAILS

G5-9015-00

Designed specifically for bow on boardings. This option includes a short aluminum bow platform with lockable storage under plus a heavy duty short pattern bow rail. Rail is canted inboard to prevent damage to other boats when alongside and to reduce the chances of tripping on the vertical stanchions as people exit forward. Ideal for fire boat applications where forward hose man requires a secure hand hold. Factory installed only.

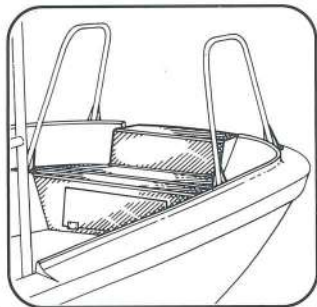

LONG PATTERN BOW RAIL W/BOARDING PLATFORM

G5-9016-00

Same features as left, with the addition of high pattern side rails extending aft to console area. Provides maximum security for passengers inside the boat. Rails vary in height from knee to waist. Factory installed only.

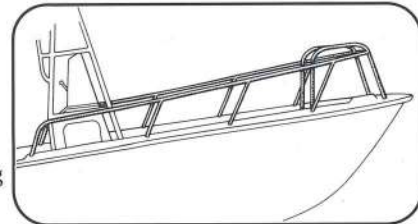

HULL COLOR & LETTERING

GELCOAT-NON-STANDARD COLORS

G5-9420-00

For hull, cabins, and consoles. Provide color chip or Federal spec number when ordering. One color inside and out. Common colors include navy grey, pure white, fireboat red and international orange. For two color combination, consult factory for pricing.

BOTTOM PAINT

5-9142-00

Hard, durable finish. Retains anti-fouling qualities even after frequent haul outs. Meets applicable Federal & State guidelines. Most common color is black. Optional colors and availability quoted on request.

LETTERING ON

HULL SIDE

G5-9430-00

Single color with accenting trim. Height to suit hull size. Up to 15 letters or numbers per side. A full range of graphic services can be provided and will be quoted upon request. Please specify lettering or special marking requirements.



HULL SLASH

G5-9430-30

A two color slash, shaped and positioned similar to Coast Guard markings. Customer should specify colors and width of the large slash to insure space for individual decals, seals, etc. Use of Imron paint makes this a durable and pleasing option.

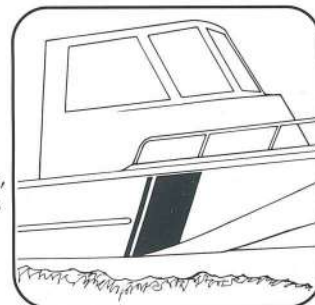

BOAT I.D. PLATE

G5-9430-20

A brass plate measuring 5" x 3" engraved with the following information:

Size and Series

Hull #

Capacity - Lbs.

Persons

Builder - Boston Whaler, Inc.

Commercial Products Division

Rockland, MA Date

Typically mounted on the console. Special wording for plate such as boat number, must be supplied by customer.

FUEL SYSTEMS

PORTABLE FUEL TANKS

Portable gas tank complete with fuel hose and primer bulb assembly. For V-4 and smaller engines. Fuel tank mat optional.

- G5-9056-00** 6 Gallon
G5-9060-00 12 Gallon



6 Gallon

FUEL FILTER

G5-9027-00

Engine manufacturer's recommended in-line filter. A must for permanent fuel tank installations. One filter per engine recommended. Note: Included in Outboard Motor Equipment package on boats with permanent fuel tanks.

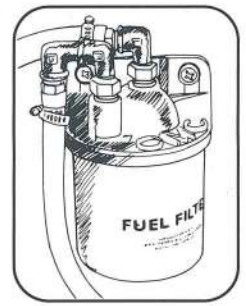

FUEL TANK MAT

12-8499-00

Protects deck from fuel tank abrasion. Has lip to retain tank. Recommended when portable six or twelve gallon tanks are used in 13'- 17' models.



ELECTRIC FUEL PRIMER KIT

15-1054-00

For use on larger models where priming engines may be difficult because of fuel line length. One primer for each engine. Larger engines such as V8 outboards may require priming system in lieu of primer bulbs.



OUTBOARD MOTOR EQUIPMENT/INSTALLATION

OUTBOARD MOTOR EQUIPMENT PACKAGE

13'-15'-17'

All essential engine accessories. Includes: Ignition and Power Trim Harnesses, Engine Controls with cables, 85 amp Battery in box, battery switch, VRO box with hold-down (OMC only), Steering System Connector, Tachometer, Trim Gauge, 6 Gallon Fuel Tank with Hose, Primer Bulb and Tank Mat.

Note: Engine controls for Utilities are side-mount and come with most engines so price does not include controls.

- G5-9180-01** 13'-15'-17' Utility-single engine
G5-9180-02 17' Guardian and 17' L.E.S. single engine*
 *Includes Binacle control.



ENGINE INSTALLATION PROGRAM

A 25 point detailed plan to ensure installation meets specifications and rigors of commercial service. Included is a dynamometer testing to ensure proper engine operation at all RPM's and under load. Engine(s) and prop(s) purchased by buyer and drop-shipped to Boston Whaler for installation.

- G5-9181-01** 13' to 15' models - single engine
G5-9181-02 17' to 25' models - single engine
G5-9181-21 19' to 27' models - dual engines
 Note: Boston Whaler can provide engines and propellers. Prices on request.

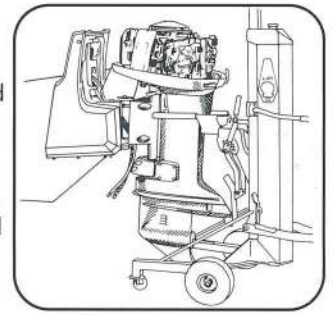

OUTBOARD MOTOR EQUIPMENT PACKAGE

19'-27'

All essential engine accessories. Includes: Ignition and Power Trim Harnesses, Engine Controls w/cables, 85 amp Battery(s) with box, VRO box(es) with holddown(s) (OMC only), Steering System Connectors, Engine Tie Bar (duals only), Tachometer, Trim Gauge(s), In-Line Fuel Filter(s), Battery Switch(s).

- G5-9180-03** 19' to 25' models - single engine
G5-9180-21 19' to 25' models - dual engines (w/hydraulic steering)
G5-9180-27 27' dual engines

SEA TRIALS

Boat is water tested using installed fuel system. Running characteristic of boat and engine(s) verified. Check with factory for availability.

- G5-9183-01** 13' to 15' models - single engine
G5-9183-02 17' models - single engine
G5-9183-03 19' to 25' models - single engine
G5-9183-21 19' to 22' models - dual engines
G5-9183-22 25' to 27' models - dual engines

OUTBOARD MOTOR EQUIPMENT/INSTALLATION cont.

PUSH TO START PANEL - FOR TWIN ENGINES G5-9519-00

Eliminates the need for keys. Start, Choke, and Stop functions are controlled by heavy duty booted push buttons. Two booted master switches energize the panel and can be mounted on the face of consoles or locked within. Red L.E.D. lights indicate power on. Note: Panel requires two engine ignition harnesses, sold individually under part number G5-9171-00, or included in the Outboard Motor Equipment Package for dual engines only.



OIL INJECTION TANK W/GAUGE

For Johnson or Evinrude with VRO systems. Used in place of the 1.8 gallon tank that comes with each engine. For single or dual engines. Conveniently mounts inside consoles, seats or within the heavy duty leaning post. Some installations will require remote fill kit (included with this kit). Factory installed only. Specify for single or dual engines.

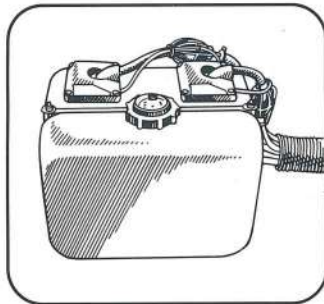

G5-9780-03 3 Gallon w/Gauge

PROPELLORS

Boston Whaler will select and purchase the most suitable stainless steel propellor for your application.

G5-9200-01 3 Cyl. and V4 Engines
G5-9200-02 V4 Workhorse, V6 and V8 Engines



95 AMP BATTERY KIT G5-9051-00

Maintenance free battery offers both cold cranking power as well as deep cycle features. Because battery is sealed it is ideally suited for installation in consoles, leaning posts, or utility boxes. 600 CCA rating. Kit includes battery box holddowns.

85 AMP BATTERY KIT G5-9050-00

Heavy duty marine grade battery housed in battery box with holddown system. Fits snugly into a special cast aluminum holder to prevent shifting. 85 AMP batteries are "Starting" batteries having a 420 CCA rating.



BATTERY TRANSFER SWITCH G5-9031-00

May be used for one engine, dual battery or dual engine, dual battery installations. Battery cables included. Note: This item included in Outboard Motor Equipment Packages. Please specify desired location.



ENGINE CONTROL SINGLE-OMC G5-9184-00

Standard equipment on single engine equipment package 17' and above except Utility models. Available for field replacement. Includes throttle & shift, plus key and kill switches.



TWIN CYLINDER STEERING UPGRADE G5-9207-00

Required when combined outboard horsepower meets or exceeds 300. System includes a high capacity helm pump and second cylinder on port engine, standard on all 27' and 30'. Optional on 22' & 25' models.

ENGINE INSTRUMENTATION FOR OUTBOARDS

Gauges are matched to engine brand. Prices include installation.

G5-9043-00 Tachometer
G5-9044-00 Voltmeter
G5-9042-00 Clock
G5-9048-00 Water Pressure
G5-9045-00 Hourmeter
G5-9172-00 Trim Gauge
G5-9047-00 Speedometer



NAVIGATION & SAFETY

RITCHIE EXPLORER COMPASS 12-0094-00

Ideally suited for 13'-17' Utilities. Has compensators to correct deviation. Lighted for night time operation. Approximately 4" in diameter. Surface mount only.



RITCHIE NAVIGATOR COMPASS 15-0160-00

Flush mount Recommended on 17' and larger models. Well dampened for rough water use. Back lit, with compensation adjustment. 4 1/2" power damp dial.



WINDSHIELD WIPERS

Quiet dependable wipers have park feature. Recommended for Sentries. Standard on Frontiers, Pilot House & Challenger models.

G5-9470-00 Dual
G5-9102-03 Single

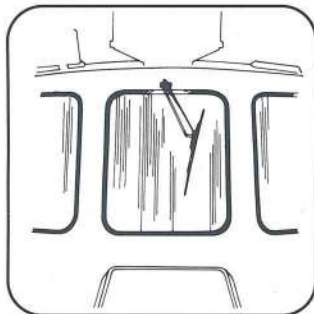

DEFROSTER FANS

G5-9540-00

Compact, quiet fans are ideal for air circulation in cabin areas. Used commonly as defroster fans with fixed and oscillating position. 12 volt. Set of 2. Standard equipment on Frontiers, Challengers and Vigilants.

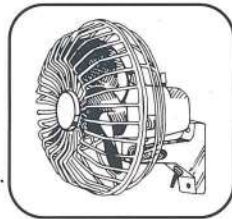

TRIM TABS

G5-9525-00

Hydraulic tabs for 19'-27' models. Toggle switches on dash permit individual tab adjustment. Ideal for trimming boat when loaded or correcting for wind induced list. Standard equipment on Frontiers, Challengers and Vigilants.

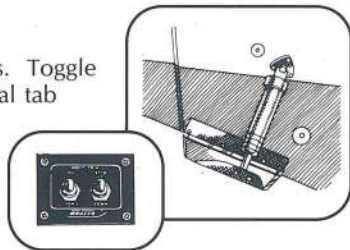

ELECTRIC HORN

G5-9150-00

A basic horn for navigational signals. Mounts in consoles and cabins. Standard on all 27' models. Available for surface or flush mounting.



ELECTRIC AIR HORN G5-9250-00

A powerful electric horn producing an "air horn" sound. Stainless construction and horn support arm make this unit suitable for marine applications. Mount in front of consoles (brackets required) or on roofs. For exceptional sound intensity order two units.

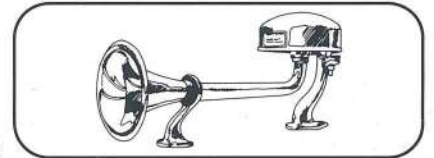

BOW DOCKING LIGHTS G5-9270-00

These powerful lights are mounted flush to the hull just below the gunwale, where they illuminate dock pilings or water obstructions without causing a blinding glare to the operator. Installation includes cutting away hull foam and reglassing cavity. Sold in pairs for boats 19' & up. Housing of light is black.



FLOOD LIGHT - HALOGEN G5-9565-00

Designed to flood working areas with a diffused light spread over a large area. Non-corrosive black casing and durable stainless bracket for easy mounting on roofs, towers, masts, etc. Measures only 7" wide X 5 1/2" high X 4" deep. Frequently mounted in pairs for added dependability.

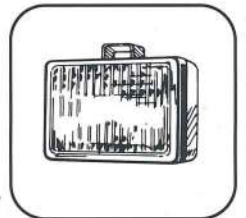

SPOTLIGHT - REMOTE HAND CONTROLLED G5-9772-00

Streamlined 225,000 C.P. (8" diameter) spotlight suitable for roof or tower mounting where the operator has access to the control handle below. Stainless construction. Blackout not available.



SPOTLIGHT - ELECTRIC G5-9350-00

This compact, lightweight spotlight develops 200,000 candlepower in a very tight beam. Because of its durability & compact size, mast mounting is desirable reducing looming effect on deck. Comes complete with touch pad control.

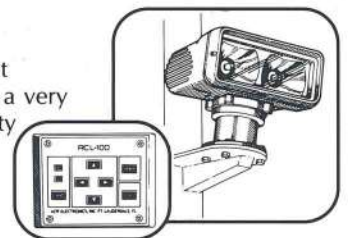

SPOTLIGHT - HAND HELD G5-9064-00

Powerful, 300,000 C.P. unit that mounts on a swivel bracket and is easily removed for searching or storage below. Rubber case protects it from damage and waterproof booted switch resists corrosion. Comes with a plug-in cord. Extra plugs may be ordered for additional remote locations.



NAVIGATION & SAFETY cont.

SPOTLIGHT - MAXA BEAM G5-9066-00

Maxa Beam's 6 million candlepower portable XENON lighting system can illuminate an object 1.5 miles away. The beam can be focused from a pinpoint spot to a 40° flood. Infrared filter provides IR illumination for night vision. Unit can be hard-wired to a 12 volt system. The rechargeable battery pack provides 90 minutes of portable operation. Package includes searchlight, power cord, rechargeable battery pack, combination quick charger/power supply, infrared filter, and a 12 volt connector.

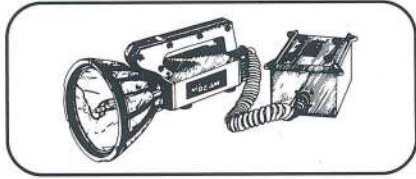

COCKPIT COURTESY LIGHT G5-9273-00

For mounting under cockpit gunwales or cabin overheads. Subdued red light reduces loss of night vision. Individually switched or wired to dash panel.



ANCHOR WINDLASS G5-9791-00

12 volt windlass w/on-off switch on windlass head. For handling line only, not chain. Mounts on models with bow decks. Please consult with factory for special reinforcement requirements.

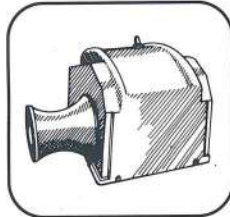

TOWING LIGHTS G5-9138-00

Available on all models except 13' and 15'. These lights consist of running lights (20 Pt. white masthead and 12 Pt. stern light) plus towing lights covering tows less than 300' in total length. The towing lights are switched separately and consist of a 12 Pt. white stern light and 12 Pt. amber light. All lights are mounted on a 6' or higher pole with one meter spacing between each light. Pole may be removable or hinged depending on model. These masthead lights replace the standard 360° light. Because of wiring and switching complexities it is recommended that this lighting system be only factory installed.

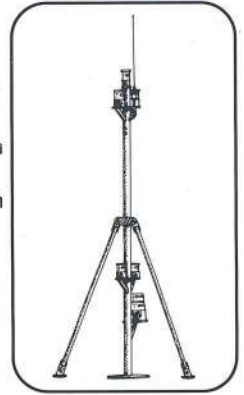

SPECIAL OPERATION LIGHTS G5-9137-00

Utilizes the same heavy duty pole as above towing lights, however, pole is lengthened to provide one meter spacing between the tandem mounted red, white, red lights. Pole typically is over 8' tall, has to be strutted for rigidity and is only available on 22' and larger models. Factory installed only.

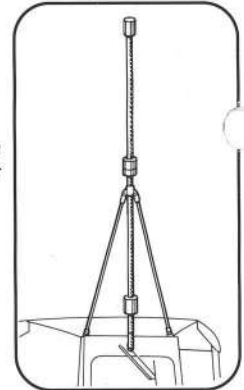

SEATING

STORAGE BOX SEAT G5-9594-00

Base is fiberglass with opening for storage. Pilot seat is standard on Vigilant and an option for the 27' Challenger.

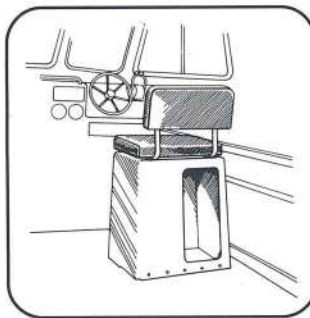

HEAVY DUTY LEANING POST G5-9032-00

Standard on 22'-27' Guardian models, optional on others. Standard width is 36" with 30" available on request. Features two lockable/plexiglass doors, a storage shelf within, grab rail and removable cushion. Room inside for two batteries and or 3 gallon VRO tank.

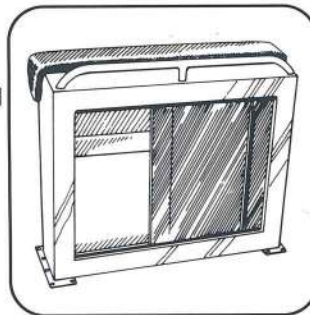

LEANING POST/STORAGE SEAT G5-9115-00

Rugged welded aluminum unit featuring our proven leaning post shape with a lockable storage box facing aft. Upper portion of leaning post includes a shelf with lockable/sliding plexiglass doors and grab rail. Room under for batteries, VRO tank, plus storage. Measures 36" wide X 30" fore and aft X 33" high. Cushions are removable. For 19' and larger models. Because of length, this unit may interfere with dive door opening on some models.

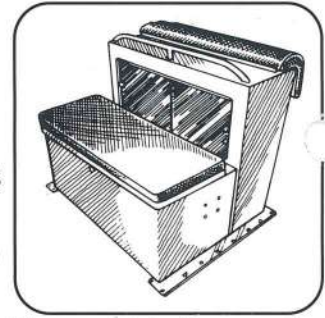

LEANING POST/AFT SEAT COMBINATION G5-9593-00

Originally designed for the 17' Dive Boat, this rugged lightweight 36" wide seat fits other models. Room under for fuel tanks or small coolers. Welded aluminum construction. Upholstery is removable.

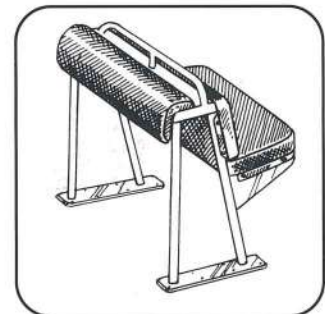

SEATING cont.

FIBERGLASS BENCH SEAT G5-9114-00

A rugged simple design that includes grab handle, removable cushions, storage shelf and space for fuel tanks, batteries or VRO tanks under. Two lockable plexi-glass doors. Standard on 17' & 19' Guardians, optional on 22' - 27' Guardians.

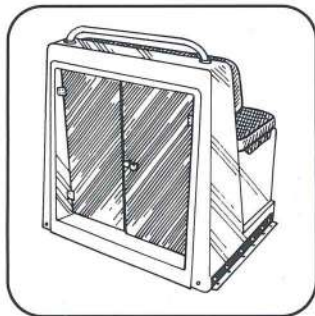

MOLDED FIBERGLASS SWIVEL SEAT G5-9361-00

Narrow profile makes this pedestal seat well suited for installation in utility models, or tandem seating in 19' and larger Guardians and Sentries. Cushions are removable. Pedestal can be cut down for height adjustment.



HEAVY DUTY PEDESTAL SEAT G5-9112-00

Standard equipment on the 27' Challenger series. This rugged seat features a 4" pedestal, 12" base, 6" slide track & stainless frame. For comfort, seat has high density contoured foam cushions, adjustable back rest, folding arms and lumbar support. A bulkhead foot-rest is also included.



FOLDDOWN SEAT G5-9590-00

This seat is standard on Frontier models: Optional on Sentry, Challenger, Vigilant and Pilot House models. Used when unobstructed stand-up operation is desired.



STERN SEAT G5-9595-00

Full-width upholstered seat contoured to conform to boat interior. Backrest is low to allow easy access to stern and engine. Stern rail gives additional strength and stiffness. 19'-25' models.

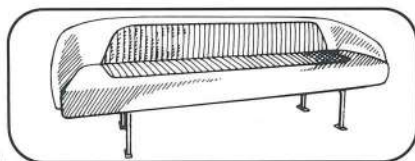

DECK UTILITY BOXES

These rugged storage boxes have lockable covers and removable cushions. Heavy bases under box elevate it slightly above the floor for drainage. Fasteners are hidden inside to prevent removal when locked.

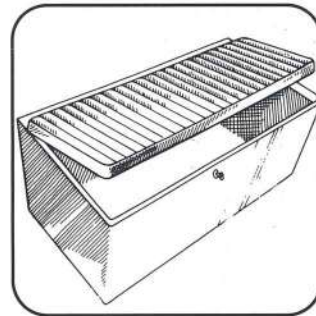

Fiberglass

G5-9555-00 36" wide X 18" deep X 13" high

G5-9556-00 Tapered 22" fwd x 38" aft x 18" deep x 13" high. Designed to fit in front of Guardian consoles.

Aluminum

G5-9557-00 50" wide x 18" deep x 13" high
Custom sizes available on request.

CUSHIONED COOLERS

These versatile coolers come with removable cushions, floor cleats and holddown cords. Ideal for dry storage or iced beverages. Shipped factory installed or loose.

15-1761-00 94 Qt. Cooler - 33" L X 16" W X 16" H

15-0431-00 162 Qt. Cooler - 41" L X 18" W X 19" H

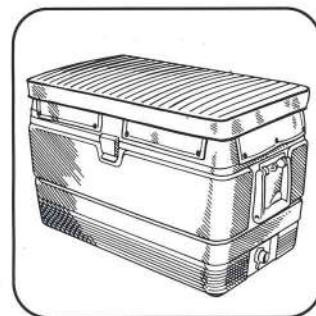

LEANING POST AFT BENCH SEAT

Developed originally to carry combat troops, this rugged seat system can also be used when extra seating or storage is required. Measures 40" wide and is 65" long for the 6 man and 90" long for the 10 man. Each seat has a wide floor mounting flange, and has four or more plastic access doors. Fits 22' or large center console models. Includes leaning post pad and large seat cushion.

G5-9541-00 6 Man

G5-9542-00 10 Man

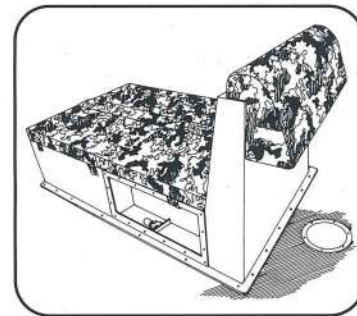

LAW ENFORCEMENT EQUIPMENT

STREAMLINED SIREN W/AMPLIFIER G5-9240-00

A good looking 100 watt siren for mounting in front of consoles (optional bracket required) on roofs or towers. Amplifier is in weather tight enclosure to prevent internal corrosion. Remote face plate is non-corrosive and matches other Whaler switch panels. Manual siren button, plus wail, yelp, PA and horn functions. Noise cancelling mike is detachable.



STROBE LIGHT WITH BUILT-IN SIREN G5-9070-00

A 12" diameter strobe with powerful 100 watt siren built into its base. Ideal for roof mounting or tower mounting if siren faces aft. Measures 12" X 12". Weighs 13 lbs. Siren amplifier is same as stream-lined unit. Specify blue or red lens. Because of its size and weight this unit is not suitable for mast mounting.



ROTATING BEACON WITH BUILT-IN SIREN G5-9065-00

Same construction and functions as G5-9070-00 strobe but with a high intensity rotating beacon. Specify blue or red lens.



SIREN/STROBE - FLUSH MOUNT G5-9063-00

Ideal for the front side of consoles, this high powered siren has the same sound quality as the Stream-lined Siren. Protrudes only 1 1/2" from the surface and houses a powerful 3" x 7" blue strobe. Amplifier with weathertight enclosure mounted inside console. Uses noise canceling mike and has PA wail, yelp, horn and manual siren functions.

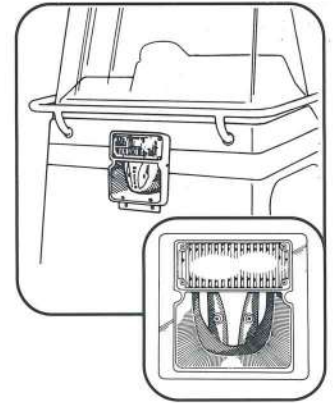

6" STROBE LIGHT G5-9067-00

Compact, high intensity strobe is ideal for roof, pole, or tower mounting. Two or more units may be installed where space permits. Self contained power source.

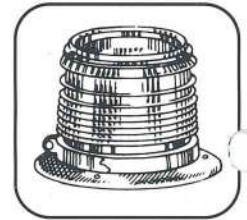

STROBE & FLOODLIGHT MAST G5-9139-00

A rugged aluminum pipe suitable for mounting our 6" strobe and up to three floodlights. Hinges on the deck and can be lowered for low bridges or garage storage. When installed, the 360 degree anchor light is mounted on top so glare does not reflect down into the boat. Designed to mount against leaning posts, fiberglass bench seats or other suitable unobstructed surfaces. Lights and strobes are optional.

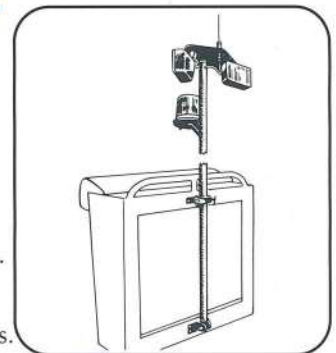

WEATHER PROTECTION

SEAT COVERS

Acrylic material is durable and fade resistant.

- 52-3657-00 Swivel Seat Cover
- 52-8374-00 Leaning Post Cover
- 52-C019-06 Bench Seat Cover
- 52-8819-00 Leaning Post/Aft Seat Cover
- 52-8821-00 Leaning Post/Storage Seat Cover
- G5-9352-00 Stern Seat Cover

CONSOLE COVERS

52-C018-07

Protects 17' - 27' Guardian Consoles when trailering or at the mooring. Note: Installation on consoles with antennas, siren brackets, etc. may require reworking for fit. Please consult factory for details and pricing.

COCKPIT SUN TENT

G5-9151-00

Available for all models 19' and up. Consists of two or more H.D. aluminum pipe bows inserted into gunwale mounted sockets. Acrylic top is fade resistant and stiffened with fiberglass sail battens and tension wires. Forward end of top can stand alone or attach to windshield or aft end of cabin roof. Please consult factory before ordering.

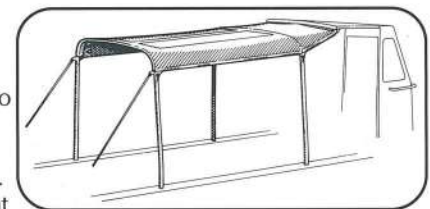

WEATHER PROTECTION cont.

SUN TOP G5-9536-00

A ruggedly simple method of providing sun protection for center console models. Fabric is a durable acrylic material that is fade resistant, and bows are stainless steel. Generally this top is centered over the driver, providing fore & aft shade. May be easily retrofitted in the field.

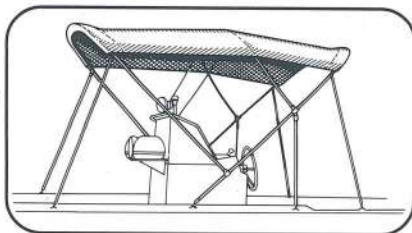

VIGILANT SUN SCREEN G5-9136-00

Designed originally for the Saudi Arabian Naval units, this top consists of aluminum forward and side overhangs, and a light acrylic covered bow structure extending approximately 4' aft of the house. Ideally suited for reducing cabin temperature plus helps prevent rain from entering open side windows. May be retrofitted on all Vigilants in the field.

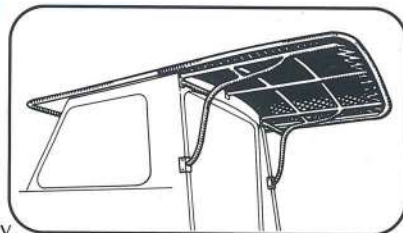

TOWING EQUIPMENT

TORSIONAL TOW BAR G5-9148-00

Tow bar spans boat from gunwale to gunwale, allowing room under for pumps or deck utility boxes. Aluminum gunwale option recommended on some models. Bolts through gunwales for strength. For 19'-25' models. Order crash rail separately.

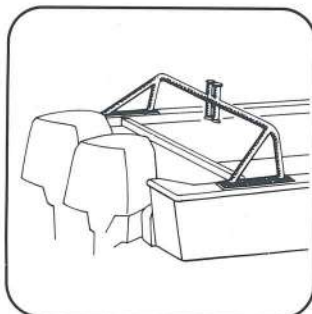

TOW POST G5-9145-00

Rugged, simple heavy duty post for 17'-27' boats. Bolts to reinforced areas within the hull. Strut tubes (19'-25') attach above the bitt for added strength and to prevent the tow line from swinging amidships. Three bolt attachment system permits easy removal when not required. Installation varies for models, sizes and options. Consult factory.

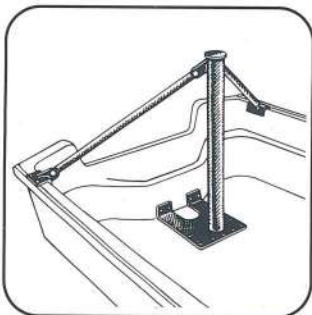

L.E.S. TOW POST TOWER G5-9346-00

Consists of a 3" pipe with tow pin and bracketed plates for a 6" strobe and up to 3 flood lights. When installed the normal 360° stern light is moved to the top of the tower. Pole is removable for low clearance situations.

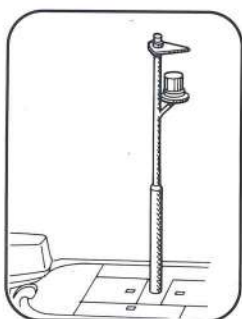

TOWING POST TOWER G5-9147-00

Same construction and attachment as Tow Post, but extended up so platform is approximately 6'6" above cockpit floor. Top of tower uses the same delta shape as the Towing Rail Tower and is strong enough to support radar dome, flood lights, antennas, etc. Flag pole and anchor light base included. For 22'-27' models.

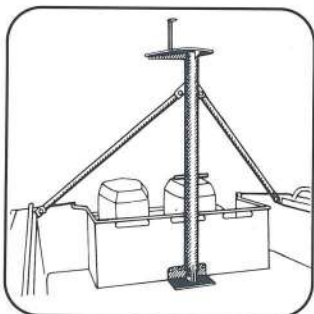

TOWING RAIL TOWER G5-9140-00

The tower provides an ideal towing system, plus the security of a crash screen in the event of tow line failure. Includes two mounting areas for antennas, an upper cross bar for sirens or floodlights, and a large platform for signals, radar dome, or additional lighting. Flag pole and anchor light base plate mount on top of platform. Factory installed only on 27' boats. Accessories include crash rail and take up reel.



TORSIONAL TOWING RAIL TOWER G5-9146-00

Starts with the same basic foundation as the successful torsional tow bar and extends upward to provide an elevated platform for lights, antennas, etc. Made from very heavy wall aluminum pipe painted black and bolted down through the lip of the gunwale. A folding upper half, and crash screen are available options. For 22' or larger models only. May be retrofitted in the field by experienced personnel with direct factory assistance by phone or fax.

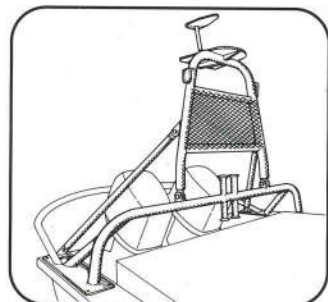

CRASH RAIL - OUTBOARD G5-4680-00

Provides protection for outboard motors when maneuvering alongside ships and docks. Rail provides excellent fair lead for tow lines, preventing fouling on engines. Order rail separately or in conjunction with any Whaler towing system. Flat black finish. For 17'-27' models.



CRASH RAIL - WHALER DRIVE G5-9149-00

Same as O.B. crash rail but extended aft for Whaler Drive applications.

TOWING EQUIPMENT cont.

TAKE-UP REEL

Heavy duty reel holds up to 250' or more of 5/8" double braid tow line listed below. Nylon axle bushing for easy movement and removable crank handle that fits either end. Tower, deck or bulkhead mountings available. Please consult factory.

G5-4685-01 Tower Mount

G5-4685-02 Deck/Splashwell Mount



TOW LINE

G2-9150-00

250' of 5/8" double braid line for maximum strength with a minimum but necessary amount of stretch. Fits Boston Whaler take-up reels. For use on 19' - 27' models. Defiance 30 and 36 requires larger diameter line.

PUSHER KNEES

G5-9335-00

Available on 17'-27' models. Constructed of heavy welded aluminum components for light weight and strength. Hulls are molded with extra glass, aluminum plates and oak blocks to accept knees. Replaceable rubber pads bolt to lead edge of knees. Flat black finish. Factory installed only.



DIVING AND RESCUE EQUIPMENT

HULL CUTOUT

For 19' and larger models, this cutout lowers entry freeboard. Hulls are molded with high tensile fibers, then cut away and glassed smooth so there are no rough edges to snag diver's suits or gear. Installed on portside only. Includes aluminum gunwale option on some models. Factory installed only.

G5-9212-34 34" Cutout (19'-27')

G5-9214-60 60" Cutout (22'-27')

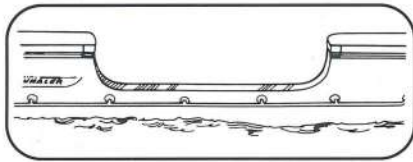

INSERT DOOR FOR HULL CUTOUT

This insert door slides in nylon tracks into the cutout opening and clamps down. Gasketed bottom edge reduces leakage and heavy duty hooks hold door in place. High density foam is inserted to prevent it from sinking. When cutout is in use, insert door is stored against the opposite gunwale in nylon chocks.

G5-9213-34 34" Door

G5-9215-60 60" Door

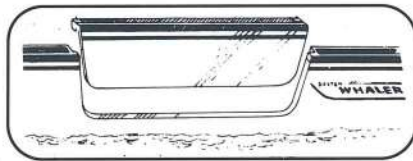

DIVE DOOR HULL CHAFE PLATE

G5-9117-00

A rugged, natural finish, stainless plate is inserted into the hull to prevent diver tanks, weights, or other objects from chipping or chafing away fiberglass. Additional hull laminates provide thicker glass for attachment screws. Plate is bedded in place. Factory installed only.

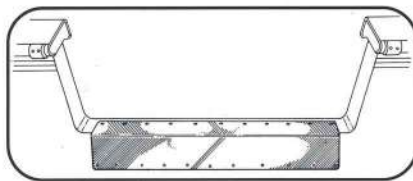

DIVER'S LADDER - FOR HULL CUTOUT

G5-9225-00

Rugged welded aluminum ladder is designed to fit 34" Hull Cutout only. Angled step design and strong hand rails make it ideal for heavily laden divers coming on board. Top step is approximately 6"-12" above waterline and bottom step about 36" below. Note: Because of size, this ladder may require special brackets for stowage. Please consult with factory for design and pricing.



DIVER'S TANK RACK

G5-9230-00

Rack is constructed with rugged welded aluminum painted to match hull interior. Each section supports 3 tanks w/flexible PVC tank holders and cam-lock webbing straps that do not mar tanks. Base of rack is cushioned with matting to prevent scarring tank bottoms. Tank rack screws to any floor surface on 15' and larger models. Custom racks available. Please consult factory.

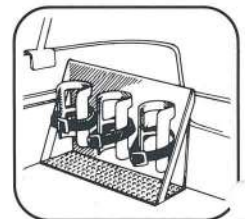

HEAVY DUTY FLAG MAST

G5-9143-00

Mounts on forward face of Guardian consoles. This is a removable, heavy tube mast designed to support up to three floodlights (optional), and a diver's flag (optional). Pole is 65" long. Flat black finish. Installation could interfere with console mounted equipment such as siren bracket.

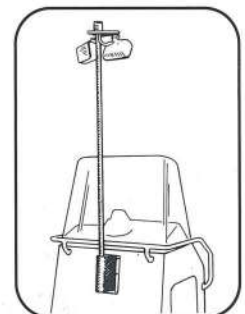

DIVER'S FLAG

12-8436-00

Measures 17" X 25". Meets applicable rules for "diver down".

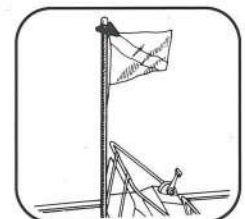

DIVING AND RESCUE EQUIPMENT cont.

RADIAL ARM DAVIT G5-9008-00

A sturdy aluminum pipe davit that will fit 17' and larger models. Designed for lifting objects up and over the gunnel. A socket at gunwale level and a base plate on the cockpit floor allow this davit to be easily removed. Reaches out approximately 24" from rub rail. Because of special inserts and heavier laminates, this option is only available factory installed. Rated for 250 lbs. Other custom davits with heavier ratings are available.

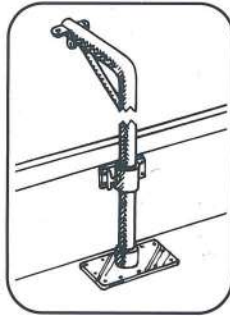

FLOOR MATTING - OPEN PATTERN G5-9237-00

A cushion type mat that covers the floor using 12" X 12" sections 1/2" thick. Open pattern allows water to drain through matting and aft into drains. Connected together with special connectors.



FOLDING DIVE LADDER

Folds compact for storage in small spaces. Stand off holds ladder away from the hull for easy boarding.

12-8435-00 17' Models
12-C061-00 19'-25' Models

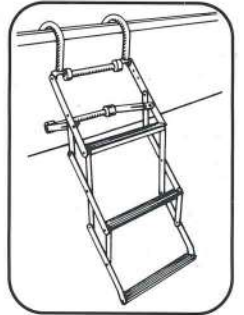

RESCUE RAILS G5-9061-00

Available for all models 13' and up. Rugged 1" stainless rails feature welded construction, over-size mounting and backing pads and stainless bolts (4 per pad) with aircraft locknuts. Note: When hull cutout is ordered the rail on the cutout side is split with a section forward and aft of the cutout.

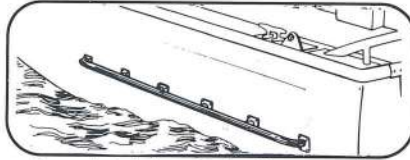

FLOOR MATTING - CLOSED PATTERN G5-9236-00

Solid diamond tread designs. Provides some cushion support and protects cockpit floor.

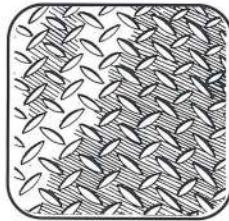

ELECTRICAL ACCESSORIES

COMMERCIAL SWITCH PANEL G5-9515-00

This compact panel measures only 3 3/4" x 8", yet holds five waterproof Airpax® breaker switches plus solid state dimmer for compass and dash lights. Also features L.E.D. on lights and backlit legends for night operations. Ideally suited for center consoles, standard on Sentry 19', 22' and 25'. Also available as supplementary switches on Challenger series. Includes wire harness with 50 amp breaker.

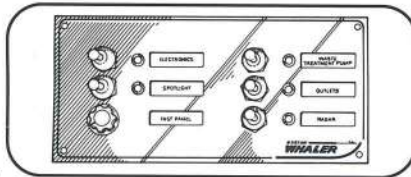

ELECTRONICS DISTRIBUTION PANEL G5-9211-00

Recommended when a variety of electronics are installed such as radios, radar, Loran, etc. Master 50 AMP breaker feeds a series of individual breakers, each labeled for individual electronic accessories. Panel mounts inside consoles or bulkheads, usually adjacent to wiring panel bus bar.

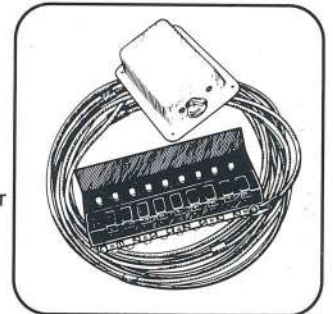

AUXILIARY SWITCH PANEL G5-9516-00

This panel is intended to supplement the commercial switch panel when additional switch functions are required. Ties into main power harness of the Commercial Panel thus cannot be used independently.

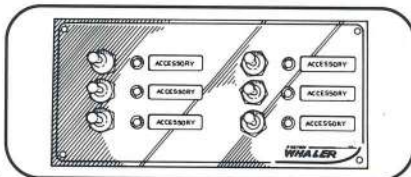

BATTERY CHARGER

Provides the convenience of plugging into 110 volt shore power and charging batteries. Includes marine type power receptacle and 25' of 30 AMP marine power line. Charger has reverse polarity warning buzzer, particularly suited for models 19' and larger. Consult factory for pricing and space limitations.

G5-9029-00 15 AMP - 2 Bank
G5-9058-00 50 AMP - 4 Bank



ELECTRICAL ACCESSORIES cont.

SHORE POWER/VOLTAGE CONVERTOR/BATTERY CHARGER

G5-9778-00

Provides 110 volt A.C. and 12 volt D.C. services for operating equipment such as electric heater, refrigerator, hot water heater, and the convenience of two 110 volt bulkhead receptacles. This 15 AMP unit charges up to three batteries. Includes marine type power receptacle, 25' of 30 AMP power line and reverse polarity warning buzzer. For 22' and larger models.

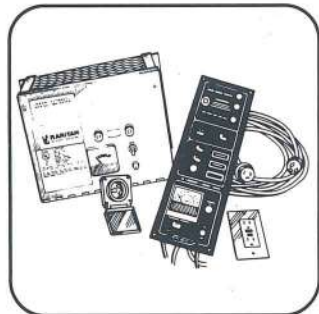

ELECTRONICS

RADIO VHF-FM

G5-9374-00

Compact weather resistant unit. All U.S.A. marine channels and 10 weather channels. Twenty memory channels, Dual Watch and Scan functions. Measures 2 1/4" high x 5 1/2" wide x 6 1/8" deep. Complete with stainless steel whip antenna. ICOM M56 or equal.



RADIO VHF-FM

G5-9375-00

Considered one of the best, this FM offers all U.S.A. Marine channels and 10 weather channels. 24 memory channels, Dual Watch and Scan functions. Measures 9" wide x 3 1/8" high by 8 1/4" deep. Complete with stainless steel whip antenna. ICOM M120 or equal.

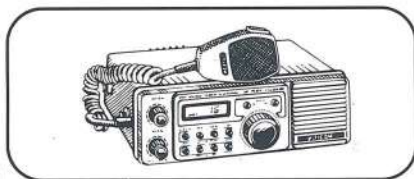

RADIO VHF-FM WITH ANTENNA

G5-9376-00

This powerful FM radio can be bracket or flush mounted. Measures 10" wide x 5" high x 3" deep. Features include water resistance, programming for all U.S., International and Canadian channels, memory function, weather channels, two channel monitoring, 25 watt output, powerful surface speaker, remote speaker jack, large L.E.D. display and two year warranty from Raytheon, Ray 90 or equal.



LORAN

G5-9388-00

A compact loran and plotter that can be bracket or flush mounted in overhead radio boxes or Guardian consoles. Measures 10" wide x 6" high by only 3" deep. Water resistant making it suitable for open boats. Provides all essential NAV and waypoint functions. Plus basic track plotting functions. Raytheon 580 or equal.



LORAN

G5-9389-00

An excellent loran, can be flush mounted in console, gauge pod or overhead radio box. Compact size, measures 9.3" wide x 4.7" high and only 3.5" deep. Large buttons make it easy to add waypoint information and rotary knob makes it convenient to change navigation mode in rough weather. Large L.E.D. readouts provide five lines of information at one time. Interfaces with most radars. Raytheon, Ray 780 or equal.

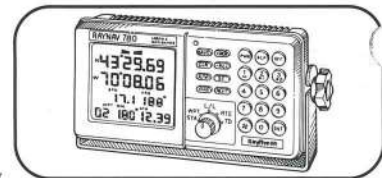

RECORDING GRAPH DEPTHFINDER

G5-9395-00

A grey line recording depthfinder with a wide range of depth selection down to 1000'. Excellent bottom definition and separation of small targets. Unit measures 8 1/2" high x 11 3/4" wide x 6 1/8" deep for mounting on top of consoles or dash areas. Water resistant construction. Supplied with transom mounted transducer for good high speed results. Lowrance X-16 or equal.



COLOR SOUNDER

G5-9396-00

Color sounder, plotter provides bottom profiles, fish locations, depth, plotter function speed and water temperature on a large multi color 8" screen. Accepts input from lorans for navigation display information. Weather resistant for installation in center consoles. Flush mounting available. Raytheon V-820 or equal.

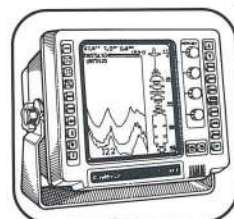

DIGITAL DEPTHSOUNDER

G5-9390-00

For depths up to 200', this flush mounted waterproof unit is ideal for dash or bulkhead mounting. Requires a 4 5/16" diameter instrument area and uses a transom mount transducer. Night time back light is controlled by a switch on the back of instrument. Datamarine S400 DL or equal.



ELECTRONICS cont.

DIGITAL MULTI-FUNCTION DEPTHSOUNDER

G5-9391-00

Flush mounted waterproof unit provides depth readings from 2 1/2' to 500' plus speed distance log, and water temperature. Hi-low alarms. Requires a 3" diameter instrument area and uses a transom mount tri-ducer. Datamarine Multi-Dart or equal.



RADAR

G5-9380-00

Compact lightweight radar with 1/4 mile to 12 mile range scales. Touch pad functions, for simplicity and weather resistance. Raster scan image for daytime operation. Dome mounts on roof top of cabin models, or on top of towing rail towers shown elsewhere in this book. Display measures 10 1/16" wide x 7 7/8" high x 12 5/8" deep and weighs 21 1/2 lbs. Raytheon R20 or equal.



RADAR

G5-9381-00

Another compact unit for small boats. This raster scan unit features a bright display for daylight operations and range scales from 1/4 to 24 miles. 10" digitized display unit measures 12 1/2" wide x 10" high x 14" deep and weighs 18 lbs. Dome measures 24" diameter, 11" high and weighs 18 lbs. Furuno 1830 or Raytheon 40x.



RADAR

G5-9382-00

A superior radar set for 25'-27' Whalers. A bright 12" raster scan screen provides navigational clarity of contacts, even in bright sun. Features electronic bearing lines, variable range markers and contact alarm for pre-set guard zones. Range scales from 1/4 to 48 miles. Indicator measures 13 1/2" wide x 15" high x 22" deep w/hood attached and weighs 24 lbs. The 4' array antenna weighs 68 lbs. Because of weight and size of this unit, special installation modifications have to be made to support structures. Please consult with factory. Furuno 8030D or equal.



HAILER/FOG HORN

G5-9397-00

This multi-function unit can be used as a hailer, listener, automatic fog horn and manual horn functions. Compact weather resistant design permits flush mounting in consoles or overhead radio boxes. Measures 10.9" wide x 5.3" high by only 4" deep. Horn included. Hailer has 30 watts output power. Raytheon, Ray 420 or equal.

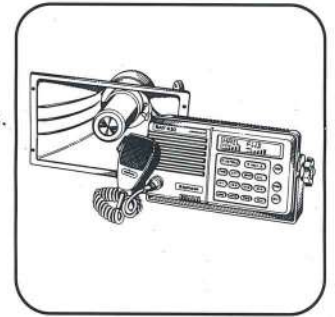

FIRE FIGHTING EQUIPMENT

PERMANENT PUMP SYSTEMS

G5-9291-00 75 H.P.

G5-9291-14 130 H.P.

G5-9291-20 225 H.P.

Includes an entire fire fighting package from intake to monitor.
Each installation will vary slightly depending on boat model.

--- ENGINE SYSTEMS

Various size marine engines are used to supply capacities shown on the chart (page 25). Each engine is fully marinized for marine use. Installation includes fresh water cooling, wet exhaust, waterlift muffler on installations below the water line, separate engine starting battery, 50 amp or greater alternator, six vibration dampening mounts and a H.D. welded aluminum engine bed drip pan mounting system. Each engine has Coast Guard approved equipment, and is run-up under full power before and after installation in the boat.

--- INTAKE SYSTEM

6" diameter, corrosion resistant suction system complete with coarse and fine strainers and cleanout connection. Intake system connected to pump with suction hose which provides flexibility and isolates engine vibration. When pump is located below water line, a 6" butterfly, shut-off valve is installed in the intake system to allow maintenance and inspection of pump without hauling boat from water.

--- PUMP/PIPING SYSTEMS

The pump is a Darley/Champion unit designed for salt water use. Pump casing is cast bronze with bronze impeller, stainless shaft and fasteners. Each pump impeller is carefully matched to each engine for optimum performance. Packing gland is adjustable and has a lifetime warranty. Discharge is through a 4" bronze standpipe into a bronze manifold with (3) 2 1/2" discharge valves. When bow monitor is used a 4" ball valve is installed as shown.

--- MONITOR SYSTEM

Bronze monitor and discharge nozzle. Uses a 4" connection from manifold to monitor. On some Guardian and Pilot House models monitor is mounted directly on top of discharge manifold through a 3" valve. On all other models a 4" discharge valve is connected to 4" diameter semi-rigid discharge leading to monitor mounted on bow.

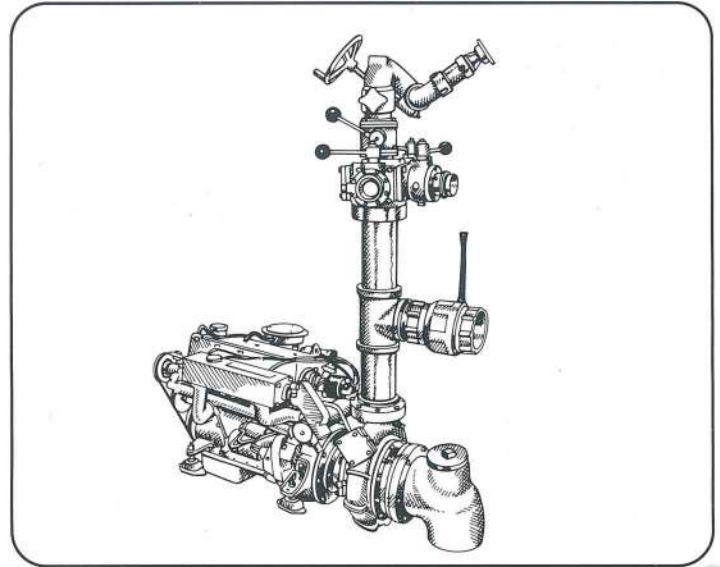

--- PRIMING SYSTEM

To prevent oil discharge into water, a positive displacement electric pump rapidly (20 seconds) primes pump whether at rest or underway. To provide redundancy a manual hand pump is installed. Both have telltale discharge outlets visually showing when prime is obtained.

--- ENCLOSURE AND VENTILATION SYSTEM

Installation arranged to provide weather protection for the pump system while ensuring proper ventilation with 12 volt blowers.

--- CONTROL AND INDICATING SYSTEM

Start/stop function, throttle and pump priming controls located at the helm station along with gauges for engine RPM, volts, cooling water temp, oil pressure and pump manifold discharge pressure.

Pump Performance: See curve on page 25.
Larger systems available up to 2500 GPM.

18 H.P. FIRE PUMP SYSTEM

G5-9296-00

Includes pump, monitor and through hull systems described below and on page 43, plus starter wiring to main ships system, quick connect fuel line to boats fuel tank, water testing under full pressure.

PORTABLE FIRE PUMP

G5-9290-00

18 H.P. gasoline engine powers a Darley fire pump modified for marine use through galvanically compatible and corrosion resistant materials. Pump casing is bronze with bronze impeller and stainless steel shaft and fasteners. Mounted on a tubular frame and secured to cockpit floor with quick disconnect fittings. All connections; electrical, fuel, suction and discharge designed for quick disconnect to make system fully portable. Standard discharge is through a two gated 2 1/2" outlets.

Performance: See curve on page 25.

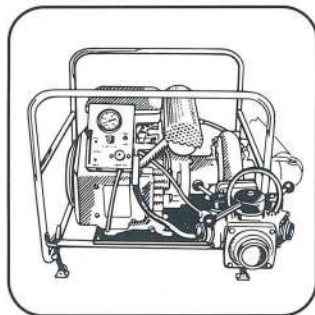

FIRE MONITOR WITH NOZZLE (for portable pump)

G5-9293-00

Monitor system consists of a 4" discharge hose from pump (3" on portable pumps), all piping and fittings required (brass or stainless steel), brass monitor, and automatic nozzle. Includes support system for mounting monitor. Arrangement will vary between boat models. Please consult with factory for details.



FIRE FIGHTING EQUIPMENT cont.

THROUGH HULL SUCTION (for portable pump)

G5-9295-00

Draws a suction without the need for over the side suction hose, thus enhancing maneuverability and making single operator operation possible. Consists of permanent fiberglass through hull fitting connected to a hard suction hose connected to the pump with an Evertight style right angle fitting.

Stainless steel coarse strainer mounted on hull exterior prevents large objects being sucked into pump. 3" diameter. Consult factory for pricing and application.

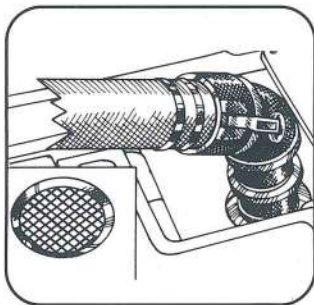

COMMISSIONING GEAR

COMMISSIONING PACKAGE

Consists of:

- Commercial Grade Life Vests (PFD's)
- Danforth Anchor with coated chain and prespliced double braid anchor line.
- Fenders
- Prespliced dock lines
- Throwable cushion or ring buoy
- 1 - Boat Hook or Paddle
- 1 - Falcon Air Horn
- 1 - Flare Kit
- 1 - First Aid Kit

Quantities and sizes/lengths depend on boat length. Consult factory for details.

G5-9575-13 13'-17' Models

G5-9575-19 19'-27' Models

G5-9575-27 30'-36' Models

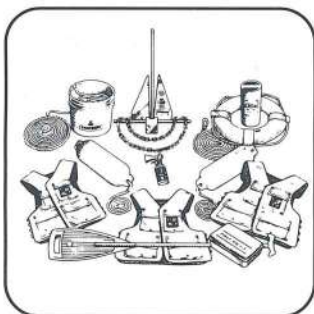

INSTALLED HEAD WITH HOLDING TANK

G5-9251-00

Manual flush toilet with installed holding tank. The waste tank can be emptied either by pumping overboard through macerator pump or by shore pump out facility through deck fitting. Salt water flush system via through-hull fitting. Available on certain models only. Please consult with factory.

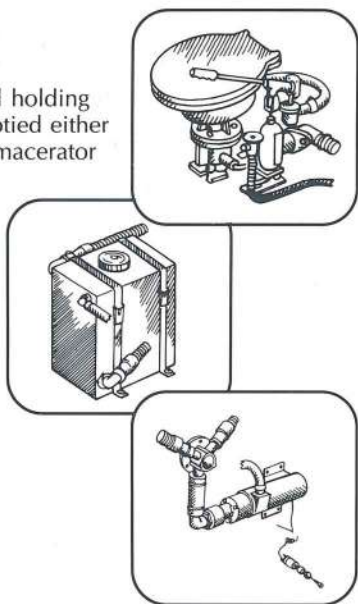

WASHDOWN SYSTEM

G5-9090-00

12-volt pump, sea suction and faucet outlet make saltwater washdowns convenient. For 19'-27' models. Consult with factory for installation locations.

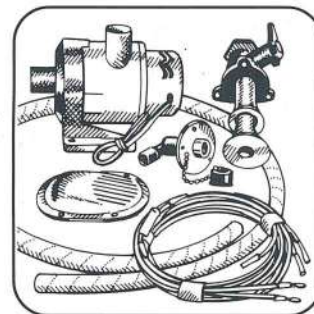

ELECTRIC HEATER

G5-9158-00

A dependable 1200 watt heater that is bulkhead mounted on 25' and larger cabin models. This heater requires 110 volt shore power system and when plugged in provides thermostatically controlled heat for over night stays, or to keep gear onboard dry and warm. Factory installed only.

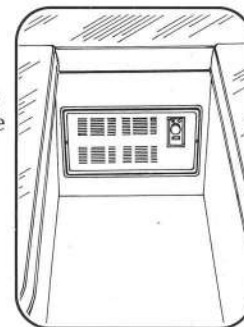

CABIN HEATER - KEROSENE

11,000 BTU'S

G5-9057-11

A compact, light weight heater/defroster, that burns clean and quiet. Ideal for winter operations for continuous heat or intermittent windshield defrosting. Draws 3.5 - 4.0 amps, has 12 volt blower, thermostat, and defroster louvers. Primarily intended for cabin models, but may be used on Sentry when canvas is flown. If used at dockside with engines shut down use optional battery charger to prevent draining battery. Unit runs 10 hours on 1 gallon. Six gallon tank is supplied; three gallons if space is restricted.

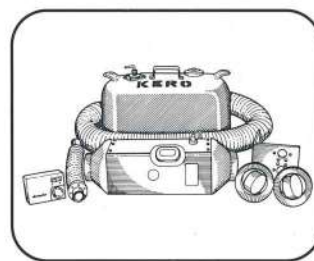

COMMISSIONING GEAR cont.

PORTABLE MARINE HEAD G5-9131-00

A light weight compact marine head suitable for limited use and where space might not permit heads with holding tanks. Contains its own water supply with an easily removable lower section that is carried ashore for dumping. Fits 22' and larger Sentries and all 25' and 27' cabin models. May be retrofitted in the field.



SHIPPING CRADLE G5-9990-00

A simple skid for storing boat level, when trailers are not ordered. Required for ocean freight shipments. When engines are shipped with boat, additional supports are required. Please consult with factory when ordering. 27' cradle shown.



CONSOLES & OPTIONS

FIBERGLASS CONSOLE G5-9348-00

Standard equipment on 17'-25' Guardians. May be retrofitted in all older Whalers. Features include heavy duty welded stainless rail, plexiglass windscreen, storage shelf and side access door. Space for key and trim switches, plus engine instruments in dash area. Base measures 34" wide X 30" deep. Height to top of windshield is 60". Shown w/optional electronics, controls and gauge panels. When ordering console for retrofit specify optional steering systems below, and color.

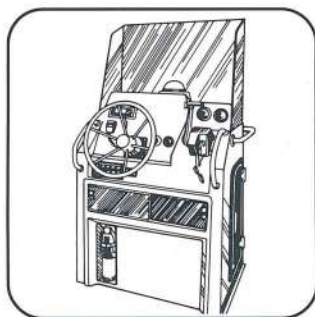

HEAVY DUTY WELDED ALUMINUM CONSOLE G5-9340-00

All welded 3/16" marine aluminum, painted with Awl-Grip to match or compliment hull interior. Aluminum construction provides unusual strength and durability. Approximate dimensions are 30" wide X 36" deep X 51" high. Designed for standup driving only. Features include welded floor mounts, aluminum watertight door, commercial switch panel, plexiglass drip cover over gauge area, lockable plexiglass cover over radio area, removable navigation light mast, and grab rails. Order steerer separately. May replace Guardian fiberglass console on 22'-27' models, or for retrofit in older Whalers.

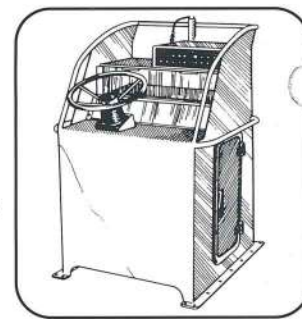

24" FIBERGLASS CONSOLE G5-9354-00

A compact console, that was originally developed for combat applications where a maximum amount of walkaround room was required. Base measures only 26 1/2" x 27 1/2". Console is wide enough to install a mechanical or hydraulic steering helm, 16" wheel, and OMC dual engine controls. Base of console is flanged on four sides for secure mounting. Fits 17' or larger models and can be retrofitted in the field.



RADAR ENCLOSURE - FOR ALUMINUM CONSOLE G5-9342-00

Radar opening in console is sized to fit, and has lockable plexiglass cover. Cover hinges up for radar tuning or clear weather use. Large radars may require reduction of radio or instrument mounting area. Please discuss with factory.

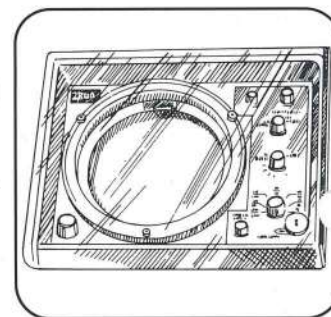

MECHANICAL STEERER - SINGLE CABLE G5-9185-00

Standard for 17' models. Includes helm unit, single cable, stainless steel wheel, and steerer connector.

MECHANICAL STEERER - TWIN CABLE G5-9186-00

Standard for 19' Guardians. Same as single cable unit above, but with a second cable to handle larger outboard motors.

HYDRAULIC STEERING G5-9187-00

Standard on 22' and 27' models, and optional on 19' model. Complete with stainless steel wheel, helm unit, two hydraulic lines and engine ram. Recommended for high horsepower and/or twin engine installations.

FOLDING SIGNAL MAST - FOR ALUMINUM CONSOLE G5-9343-00

Heavy duty mast is all welded aluminum, and designed for installation on welded consoles only. Folds forward for bridge clearance. Ideal for mounting lights, sirens, or antennas. Flagpole and anchor light are standard. Area under platform useful for installing electrical connections such as bus bars.



CONSOLES & OPTIONS cont.

STORAGE/RADIO BOX

G5-9231-00

Box inserts into console. Face includes lockable, hinged door cover and mounting pan for electronics.

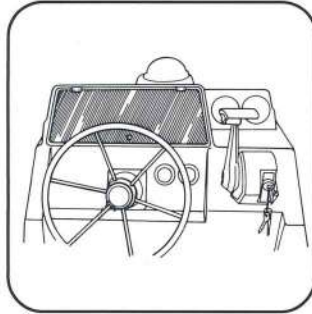

FIRE EXTINGUISHER

12-0124-00

2 1/2 pound dry chemical fire extinguisher with mounting bracket.

FIRE EXTINGUISHER POCKET

G5-9770-00

A fiberglass pocket for additional extinguishers on the console, or any bulkhead location. Extinguisher not included.

WATERTIGHT DOOR

G5-9771-00 Small 8 3/4" X 18 1/2"

G5-9360-00 Large 11" X 28"
Heavy duty door with matching frame. Positive closure against a large gasketed surface for maximum spray protection. One door is standard on all consoles. Additional door may be mounted on the opposite side.



MEDIUM DUTY "T"-TOP

G5-9349-00

This top was designed for commercial service. Tube size and fastening systems were taken into account. The top measures 56" x 64" long and consists of a laced acrylic fabric over aluminum bows.

at aluminum plates are located under the canvas for antennas, strobes, sirens, etc. An aerodynamic fiberglass radio box is slung under the top for flush mounting radios, etc. Included with the "T"-Top package are heavy duty console floor cleats. May be retrofitted to Guardian III consoles in the field. Consult factory for crating and shipping details.

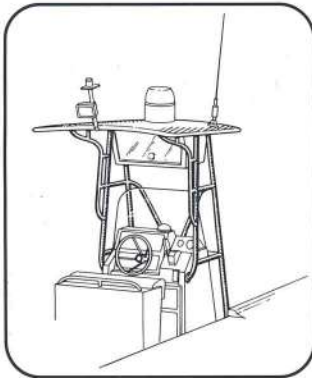

HEAVY DUTY "T"-TOP ASSEMBLY

G5-9103-00

Same size and configuration as the medium duty unit, but with heavier tubing, custom built welded aluminum radio box, aluminum top surface and heavily reinforced floor and hull structure. Supports up to 150 lbs. Factory installed only.

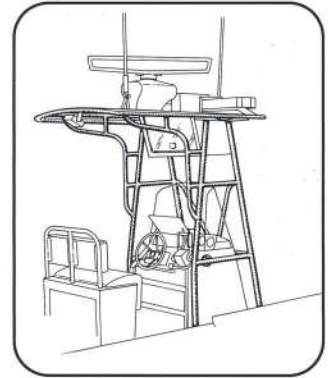

"T"-TOP WEATHER CURTAIN SYSTEM

G5-9103-01

An option for either the H.D. or Medium Duty "T"-Tops, completely encloses operator with forward curtain, P/S side curtains and a rear drop curtain. Rugged acrylic material with non-corrosive zippers and snaps. On smaller models (19-25') trim tabs are recommended to correct for list caused by strong cross winds, and to prevent wind induced porpoising at high speeds.

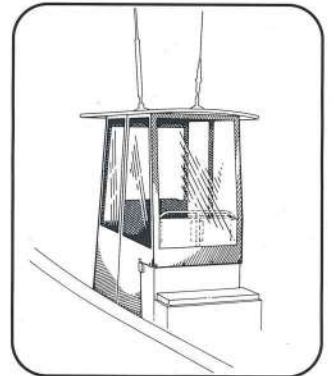

WINDSHIELD "T"-TOP W/SAFETY GLASS WINDOWS

Provides additional weather protection for center console models. Front and side windows are safety plate set into H.D. rubber extrusions. Sun top provides shade for driver with optional side and rear drop curtain available. Headroom is 6'4". Includes rails as shown. May be retrofitted to newer Guardian consoles. Please consult factory before ordering.

G5-9102-00 Windshield "T"-Top
G5-9102-01 Weather Curtain Set

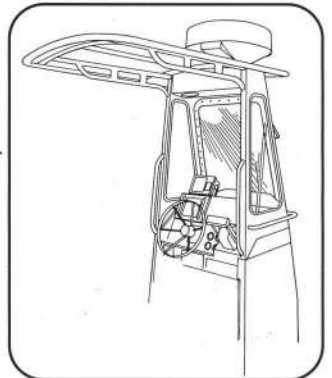

SPECIAL PURPOSE ITEMS

TRIPOD G5-9152-00

This rugged stainless steel tripod is designed for either 7.62 or .50 caliber machine guns, or the 40mm MK 19 grenade launcher. Comes with a bronze stand with train stops, but gun cradle must be ordered separately. When installed, deck and hull structure are very heavily reinforced with additional fiberglass aluminum inserts and frequently an aluminum deck plate. Because of strength requirements, this option can only be factory installed.

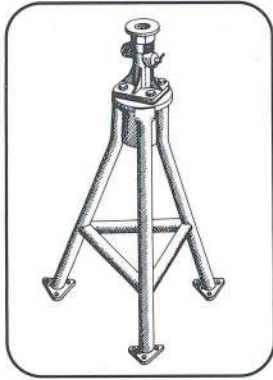

GUNWALE MOUNT TRIPOD* G5-9153-00

Same rugged tripod as the tripod above, except one leg has been modified so tripod can rest on a heavily reinforced gunwale section. Includes stand, with train stops, but cradle (either 7.62 or .50 caliber) must be ordered separately. Because of total weight, it is only available on 25' & 27' models.

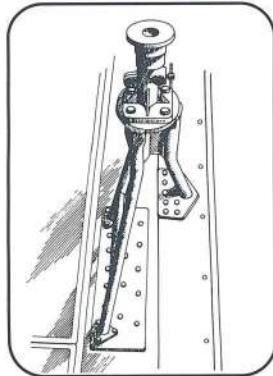

PLUG-IN 7.62 PEDESTAL MOUNT WITH CRADLE G5-9154-00

This pedestal inserts into a deck or gunwale socket and is designed to be removable or to add extra mounts when situation requires additional fire power. Deck or gunwale areas are reinforced to accept a 12" diameter base. Socket penetrates approximately 6". System comes complete with socket, pedestal, train stops and 7.62 gun cradle with ammo box. Specify type and manufacturer of 7.62 when ordering.

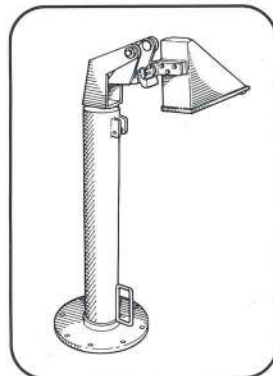

7.62 CRADLE G5-9161-00

A stainless steel cradle (shown bottom left) designed to fit 7.62 sized machine guns. Includes pintle, cradle, depression stop and ammo can holder. Specify type and manufacturer of 7.62 when ordering.

.50 CALIBER SOFT MOUNT G5-9152-01

Designed for .50 caliber heavy barrel or aircraft barrelled machine guns. Comes complete with shock absorbing cradle assembly, pintle and ammo can holder. Requires installation of heavy duty tripod. Available for retrofit in the field.

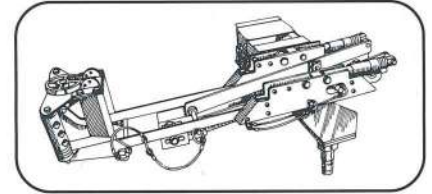

GUNWALE QUARTER MOUNTS* G5-9160-00

These pipe pedestals are welded to Boston Whaler's optional aluminum gunwales and are integrated into the high pattern side rail system. Suitable for 7.62 machine guns, these mounts include a non-metallic socket bearing and train stops. One or more pedestals may be mounted on each gunwale or onto tow bar systems. Cradle assembly ordered separately. This option available only factory installed.

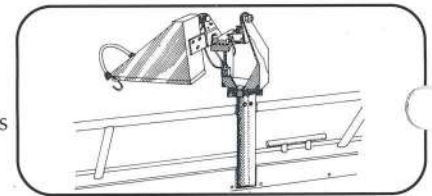

* Requires Aluminum Gunwale Upgrade Kit.

WARRANTIES

STRONGEST BOATS... STRONGEST WARRANTY

Boston Whaler® Powerboat Limited Warranty

For the protection of its customers, Boston Whaler, Inc. offers:

- (1) **A Limited Ten-Year Warranty for the Hull Structure.**
- (2) **A Limited Two-Year Warranty for Accessories supplied by Boston Whaler, Inc. other than engines.**
- (3) **A Limited One-Year Warranty for Cosmetic Finishes.**

1. Boston Whaler, Inc. provides each new boat with a warranty registration card which must be filled out and mailed to Boston Whaler, Inc. promptly after purchase, to help us fulfill our service obligations to our customers, and our legal obligations of the Federal Boat Safety Act. FAILURE TO COMPLETE AND RETURN THE WARRANTY REGISTRATION CARD WITHIN 30 DAYS OF DELIVERY OF YOUR BOAT TO YOU WILL VOID THE WARRANTY.
2. Boston Whaler, Inc. warrants each Boston Whaler hull manufactured by Boston Whaler, Inc. to be free from **structural** defects due to substandard material and workmanship, under conditions of normal consumer use and service, for a period of **ten years** from date of manufacture.
3. **Accessories** supplied by Boston Whaler, Inc. whether or not manufactured by Boston Whaler, Inc. (other than the engine assemblies, which are warranted by the engine manufacturers and not by Boston Whaler, Inc.) are warranted against defective workmanship or materials for a period of two years from date of delivery to the original purchaser. (Built-in fuel tanks are considered an accessory component).
4. Boston Whaler, Inc. warrants each hull supplied by Boston Whaler, Inc. to be free from **cosmetic** defects due to substandard materials or workmanship, under conditions of normal use and service, for a period of **one year** from date of delivery to the original purchaser.
5. None of the foregoing hull and accessory warranties applies to any Boston Whaler boat which has been structurally altered, subjected to unreasonable use, negligence or accident, or used for racing purposes. These warranties are also void if the manufacturer's maximum recommended horsepower is exceeded. The recommended horsepower is shown on the certification plate affixed to the hull.
6. The obligation of Boston Whaler, Inc. under these warranties is limited to repairing, replacing or make reimbursement within a reasonable time, such boat or part which shall, within the warranty period be determined to have been

defective in material or workmanship. The decision to repair, replace or make reimbursement for a particular boat or parts shall be at the election of Boston Whaler, Inc. Replacement or reimbursement for such boat or part will be prorated for use according to the portion of the warranty period elapsed when the claim is made. Boston Whaler, Inc. may require such boat or part to be returned to an authorized dealer or the factory for examination, transportation charges prepaid. Boston Whaler, Inc. will reimburse these charges upon disclosure of a bona fide warranty claim.

BOSTON WHALER, INC. MAKES NO OTHER EXPRESS WARRANTIES, AND INTENDS NO IMPLIED WARRANTIES. IF ANY IMPLIED WARRANTIES BE FOUND TO EXIST, SUCH IMPLIED WARRANTIES WILL BE SUBJECT TO THE TIME LIMITS APPEARING AT THE TOP OF THIS WARRANTY. SOME STATES DO NOT ALLOW LIMITATIONS ON HOW LONG AN IMPLIED WARRANTY LASTS, SO THE ABOVE LIMITATIONS MAY NOT APPLY TO YOU. BOSTON WHALER, INC. WILL NOT BE LIABLE FOR CONSEQUENTIAL DAMAGES OF ANY KIND RESULTING FROM A BREACH OF ANY WARRANTY EXPRESSED OR IMPLIED. SOME STATES DO NOT ALLOW THE EXCLUSION OR LIMITATION OF INCIDENTAL OR CONSEQUENTIAL DAMAGES, SO THE ABOVE LIMITATION OR EXCLUSION MAY NOT APPLY TO YOU.

7. Boston Whaler, Inc. reserves the right to improve its products through changes in design or material without obligation to incorporate such changes on boats of prior manufacture.
8. To initiate a warranty claim, it is the responsibility of the purchaser to contact an authorized Boston Whaler dealer or Customer Service Department at Boston Whaler, Inc., 1149 Hingham St., Rockland, MA 02370 within a reasonable time after discovery of the defect giving details as to the nature of the problem, hull serial number, date of purchase and from whom, and circumstances of the defect, and delivering to such dealer the boat with respect to which the warranty claim is made.
9. This warranty is not limited to the original purchaser. It is transferable to all future owners of the boat.
10. This warranty gives you specific legal rights and you may have other rights which vary from state to state.

Boston Whaler, Inc., 1149 Hingham Street
Rockland, MA 02370

Boston Whaler® Defiance Aluminum Boat Warranty

For the protection of its customers, Boston Whaler, Inc. offers:

- (1) **A Limited Five Year Warranty for the Hull Structure.**
- (2) **A Limited Two-Year Warranty for Accessories supplied by Boston Whaler, Inc. other than as itemized in Paragraph 3 below.**
- (3) **A Limited One-Year Warranty for Cosmetic Finishes.**

1. Boston Whaler, Inc. provides each new boat with a warranty registration card which must be filled out and sent to Boston Whaler, Inc. promptly after purchase, to help us fulfill our service obligations to our customers, and our legal obligations under the Federal Boat Safety Act. FAILURE TO COMPLETE AND RETURN THE WARRANTY REGISTRATION CARD WITHIN 30 DAYS OF DELIVERY OF YOUR BOAT TO YOU WILL VOID THE WARRANTY.
2. Boston Whaler, Inc. warrants the DEFIANCE hull to be free from **structural** defects due to substandard material and workmanship, under conditions of normal use and service, for a period of **five years** from date of manufacture. This warranty is void if owners install components to the hull, above or below the waterline, that are not compatible with aluminum. This includes but is not limited to steel, brass or bronze. Owners should contact factory before additions or alterations are made to DEFIANCE hulls or cabins.
3. **ACCESSORIES** supplied by Boston Whaler, Inc., whether or not manufactured by Boston Whaler, Inc., are warranted against defective workmanship or materials for a period of **two years** from date of delivery to the original purchaser with the exception of the following items which are covered by the warranties of the respective manufacturers:
 - A. Engines, whether outboard, inboard, inboard/outboard, Seadrives®, gasoline or diesel; the manufacturer's warranty applies even when Boston Whaler, Inc., sells the engine to the buyer.
 - B. Batteries.
 - C. Electronics, including but not limited to radar, radios, lorans, depth and speed meters, sirens and loud hailing systems.
 - D. Electrical generators.
 - E. Fire pump engines.
 - F. Any equipment supplied by the buyer for installation by Boston Whaler, Inc.
4. Boston Whaler, Inc. warrants the DEFIANCE hull to be free from **COSMETIC** defects due to substandard materials or workmanship under conditions of normal use and service for a period of **one year** from date of delivery to the original purchaser.

5. None of the foregoing hull and accessory warranties applies to any DEFIANCE which has been structurally altered, subjected to abuse, negligence or accident, or used in combat (see COMBAT WARRANTY).
6. The obligation of Boston Whaler, Inc. under these warranties is limited to the repair, replacement or making reimbursement within a reasonable time, for such boat or part which shall, within the warranty period, be determined to have been defective in material or workmanship. The decision to repair, replace or make reimbursement for a particular boat or parts shall be at the election of Boston Whaler, Inc. Replacement or reimbursement for such boat or part will be prorated for use according to the portion of the warranty period elapsed when the claim is filed. BOSTON WHALER, INC. MAKES NO OTHER EXPRESS WARRANTIES, AND INTENDS NO IMPLIED WARRANTIES, IF ANY IMPLIED WARRANTIES BE FOUND TO EXIST, SUCH IMPLIED WARRANTIES WILL BE SUBJECT TO THE TIME LIMITS APPEARING AT THE TOP OF THIS WARRANTY. SOME STATES DO NOT ALLOW LIMITATIONS ON HOW LONG AN IMPLIED WARRANTY LASTS, SO THE ABOVE LIMITATION MAY NOT APPLY TO YOU. BOSTON WHALER, INC. WILL NOT BE LIABLE FOR CONSEQUENTIAL DAMAGES OF ANY KIND RESULTING FROM A BREACH OF ANY WARRANTY EXPRESSED OR IMPLIED. SOME STATES DO NOT ALLOW THE EXCLUSION OR LIMITATION OF INCIDENTAL OR CONSEQUENTIAL DAMAGES, SO THE ABOVE LIMITATION OR EXCLUSION MAY NOT APPLY TO YOU.
7. Boston Whaler, Inc. reserves the right to improve its products through changes in design or material without the obligation to incorporate such changes on boats of prior manufacture.
8. To initiate a warranty claim, it is the responsibility of the purchaser to contact the COMMERCIAL PRODUCTS DIVISION OF BOSTON WHALER, INC., located at 1149 Hingham Street, Rockland, MA 02370, within a reasonable time after discovery of the defect, giving details as to the nature of the problem, hull serial number, date of purchase and from whom, and circumstances of the defect.
9. This warranty is not limited to the original purchaser. It is transferrable to all future owners of the boat. Any transfer of the boat to a new owner shall not extend the period of any warranty made by Boston Whaler, Inc.
10. This warranty gives you specific legal rights and you may also have other rights which vary from state to state.

Boston Whaler, Inc. 1149 Hingham Street
Rockland, MA 02370

CLIENT LIST

We are proud to have served the following agencies:

FEDERAL AGENCIES

United States Navy
United States Coast Guard — Active, Reserve, Auxiliary
United States Marine Corps
United States Customs Service
United States Drug Enforcement Agency
United States State Department
United States Air Force
United States Army

United States Army Corps of Engineers
United States Immigration & Nat. United States Geological Survey
United States Border Patrol
United States Forest Service
United States Dept of Public Safety
United States Fish & Wildlife Service
NOAA
NASA

National Park Service — Various Locations
National Marine Fisheries Service
American Embassy Pakistan
American Embassy Nigeria
American Embassy Zaire
United States Dept of Interior
United States Dept of Energy
Federal Bureau of Investigation
Federal Highway Administration

Bureau of Reclamation
United States Environmental Protection Agency
Gulf Island National Seashore
Fire Island National Seashore
Christianssted NHS, VI
Apostol Island National Seashore

U.S. STATES

Alabama
Alaska
Arizona
Arkansas
California
Colorado
Connecticut
Delaware
Florida
Georgia
Hawaii
Illinois

Indiana
Louisiana
Maine
Maryland
Massachusetts
Michigan
Minnesota
Mississippi
Montana
Nevada
New Hampshire
New Jersey

New Mexico
New York
North Carolina
Ohio
Oklahoma
Oregon
Rhode Island
South Carolina
South Dakota
Tennessee

Texas
Utah
Vermont
Virginia
Washington, D.C.
Washington
West Virginia
Wisconsin

COUNTY OF

MohaveAZ
AlamedaCA
OrangeCA
LeeFL
Metro DadeFL
St. Joseph'sFL

AntrimMI
Santa ClaraCA
Los AngelesCA
BranchMI
HuronMI
MissoulaMT

HerkimerNY
SuffolkNY
HamiltonOH
LucasOH
SummitOH
PickawayOH

SciotoOH
FairfaxVA
KingWA
WayneNY
VolusiaFL
BerkeleySC

CITY OF

BullheadAZ
BerkeleyCA
Los AngelesCA
San DiegoCA
San FranciscoCA
San Joaquin ValleyCA
Santa BarbaraCA

DanburyCT
HartfordCT
DoverDE
Indian Harbor BeachFL
MiamiFL
ChicagoIL
LowellMA

BaltimoreMD
HollandMI
OttawaMI
ManchesterNH
Jersey CityNJ
Somers PointNJ

AlbanyNY
New YorkNY
PoughkeepsieNY
PittsburghPA
Virginia BeachVA
San JoseCA

TOWN OF

Jupiter IslandFL
BarnstableMA
EdgartownMA
HinghamMA
MarionMA

ShrewsburyMA
YorkME
Oak BluffsMA
NaplesME

BrickNJ
WoodbridgeNJ
BedfordNY
HempsteadNY

SmithtownNY
MarbleheadMA
HuntingtonNY
SoutholdNY

FIRE DEPARTMENTS

Lower Alloways Creek Fire Department, NJ
Buckskin Fire Department, AZ
Noroton Fire Department, CT
Norwich Fire Department, CT
Weathersfield Fire Department, CT
Holloway Fire Department, DE
Ft. Lauderdale Fire Department, FL
Gulf Breeze Fire Department, FL

Indian River County Fire Department, FL
Jacksonville Fire Department, FL
Melbourne Fire Department, FL
Nanjemoy Fire Department, FL
Reddington Fire Department, FL
City of Sarasota Fire Department, FL
Beverly Fire Department, MA

Cotuit Fire Department, MA
Annapolis Fire Department, MD
Baltimore Fire Department, MD
Baltimore County Fire Department, MD
Sunrise Beach Fire Department, MO
Carlstadt Fire Department, NJ
Hamburg Fire Department, NY

Owasco Fire Department, NY
Port Jefferson Fire Department, NY
Wilson Fire Department, NY
Bedford Fire Department, PA
Dunfries Fire Department, VA
Fairfax Fire Department, VA
Owl Fire Department, VA
Washington Fire Department, DC

POLICE DEPARTMENTS

Stamford Police Department, CT
Westbrook Police Department, CT
Westport Police Department, CT
Waterford Police Department, CT
Ft. Lauderdale Police Department, FL
Miami Police Department, FL

Boston Police Department, MA
Chatham Police Department, MA
Metropolitan District Police, MA
Annapolis Police Department, MD
City of New York Police Department, NY

Putnam Valley Police Department, NY
Perrysburg Police Department, OH
Port Clinton Police Department, OH
Sandusky Police Department, OH
Vermilion Police Department, OH

Memphis Police Department, TN
Metropolitan District Police, DC
Lake Geneva Police Department, WI
Milwaukee Police Department, WI
Jacksonville Police Department, FL
Guam Police Department

EDUCATIONAL FACILITIES

University of Idaho
Louisiana State University
Michigan State University
Wesleyan University

San Diego State University
University of California
George Mason University
Saddleback College

Auburn University
Tabor Academy
Oklahoma State University
Smith College

Lewis & Clark State
Smithsonian Institution
Moss Landing Marine Lab
University of Alaska

TRANSPORTATION AUTHORITIES

Kennedy Airport
LaGuardia Airport

NY/NJ Port Authority

Washington National Airport

Tennessee Valley Authority

INDUSTRY

Alaska Overseas Fisheries
Bistate Oil Co.
Boy Scouts of America
Commonwealth Oil Co.
Hope Brook Gold

Inter American Tuna Commission
Mobil Oil
Occidental Petroleum
Pan Am
Petrola International

PSI Energy
Roy F. Weston, Inc.
Smithsonian Institution
Star Enterprises

Texaco
Tropical Tuna Commission
United Airlines
Sea Tow

FOREIGN COUNTRIES

Abu Dhabi
American
Samoa
Bolivia
Botswana
Brazil

Canada
Colombia
Ecuador
Bahrain
Bermuda
Great Britain

Guyana
Micronesia
Truk
Virgin Islands

Peru
Saudi Arabia
Macru Government

WHALER UNSINKABLE WORKBOATS



17' Guardian



25' Frontier



25' Challenger



19' Sentry



Three of Mohave County Sheriff's four Sentries under an authentic transplanted London Bridge.



17' Guardian



株式会社 マツイ

東京本社
札幌支店
仙台支店
大阪支店
福岡支店
鈴鹿工場
海外法人

〒106	東京都港区麻布台2丁目4-7	TEL (03) 586-4141	FAX (03) 583-9016
〒060	札幌市中央区北四条西7丁目1-5	TEL (011) 261-3301	FAX (011) 271-7006
〒983	仙台市卸町東1丁目1-33	TEL (022) 284-8881	FAX (022) 284-8885
〒551	大阪市大正区三軒家西1丁目1-11	TEL (06) 552-1151	FAX (06) 551-1122
〒812	福岡市博多区博多駅南2丁目14-7	TEL (092) 441-1851	FAX (092) 441-1855
〒510-02	三重県鈴鹿市白子1丁目18-6	TEL (0593) 86-1113	FAX (0593) 86-0721

MATSUI U.S.A. CORPORATION CALIFORNIA U.S.A.

