

# Boston Whaler presents a look at what's new for 1991.





# New designs. New



*New 16 SL*

In 1991, we're introducing seven new boats at Boston

single year. But new boats are just the beginning. There's also a unique

when we introduced the world's first



*New 21 Walkaround*

unsinkable

the center console revolution by unveiling



*New 27 Walkaround*

into the

when we launched the first deep-vee

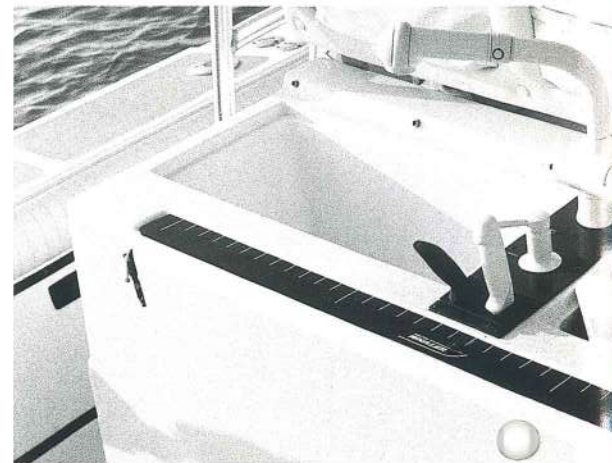

*Here's one example of our approach to design at Boston boat—the fully functional workstation aboard our new boat—from salt and fresh running water to cutting board lids*

It's an approach driven by innovation. By a desire to build boats for the



*New Offshore 27*

safest, strongest, most reliable boats anywhere. And it's

for another 30 years.

# ideas. New solutions.

Whaler,



more than we've ever presented in a

approach to design. An approach as fresh today as it was back in 1958

hull. And in 1961, when we pioneered



*Whaler, an approach based on how you really use the Offshore 27. Note the attention to detail, with everything and fillet knife holders.*

the 16-foot Nauset, which later evolved

Montauk 17. And once again in 1978

hulled Boston Whaler, the Outrage 22.

way people really use them. By a commitment to making them the

sure to yield new designs, new ideas and new solutions



*New Whaler 31L*





# But there's nothing new about the safest, strongest, most



You've seen it before. A chain saw ripping through the hull of a 13-foot Whaler, exposing the solid core of closed-cell foam but failing in its attempt to sink the little boat.

It was a demonstration we conceived over 30 years ago to prove the inherent safety of every Boston Whaler. But it's not the only proof. You can also pull the plug on one of our 17-foot Montauks, overload it with ten people, and as the photo illustrates, the Whaler will still float high enough to keep the engine's powerhead safely above water. Our competitor's 17-footer, on the other hand, lacks the buoyancy to support only five people with the plugs pulled.

Our unique foam-core, Unibond™ construction is the rea-

son. First, we lay up an inner and outer skin of fiberglass, then join the two molds while the resin has yet to cure. We quickly inject foam into the cavity between, which expands rapidly under tremendous pressure, filling the entire structure from gun-

nel to gunnel. Because the resin is still wet, the foam and fiberglass chemically bond, creating a one-piece hull that's incredibly strong and inherently buoyant.

So buoyant, in fact, that Boston Whaler® hulls have 2½ times the



*Boston Whaler*



*The Competition*



# the fact that Boston Whalers are reliable boats in the world.

minimum Coast Guard requirement for positive flotation.

So strong that Boston Whalers have even been known to withstand the trials and tribulations of life in the demolition area. Every so often our quality control people reject a hull and they send it off to be destroyed. The problem is, a Boston Whaler hull is so tough, a 44,000 lb. bulldozer can sit on top without crushing it. Proof of the incredible strength and rigidity designed

into each and every Boston Whaler hull.

If you want more proof, consider the fact that Boston Whalers are used by more government agencies than any other boat. One reason is the way we build them. Another reason is our warranty. While most companies void theirs in the case of government or



commercial use, we have the confidence to stand behind our hulls for ten full years, no matter how hard they're used.

If you're seriously considering a boat, you should know that each and every Whaler, from our 9-foot Tender to the new 31L, is built to the same rigid standards previously described. Not surprisingly, they're also the same rigid standards that have set Boston

Whalers apart for over three decades.

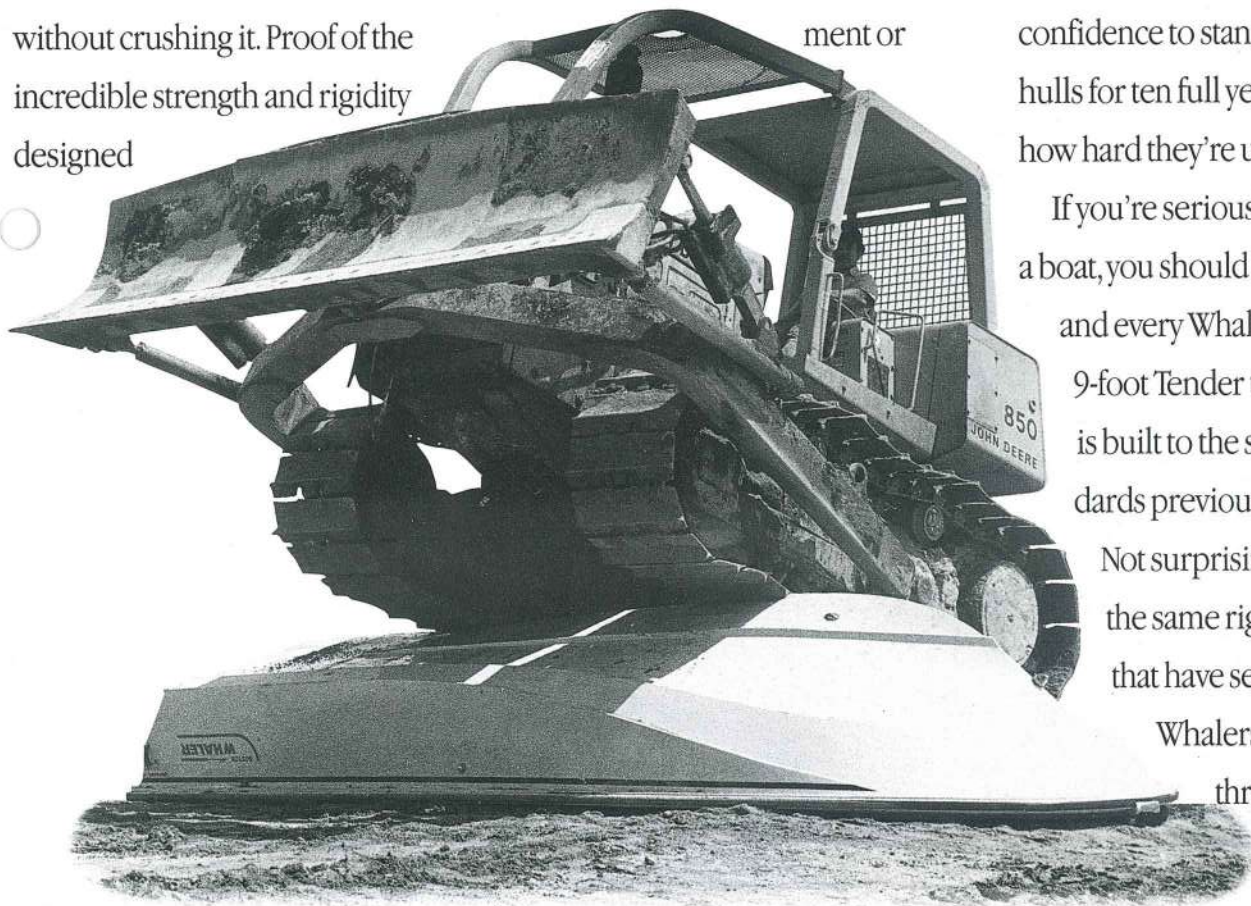



# Whaler 31L

Our new 31L is positive proof that you don't have to sacrifice belowdecks comfort for exceptional fishing. Or vice versa. On deck, it has a large fish box, transom door and dual prep centers with removable tackle boxes, live bait well and a double sink with both fresh and salt water. Below, you'll find a wide open interior accented with handsome oak trim, and modern white counter tops and sink fixtures. All protected by our foam-core Unibond™ constructed hull. Absolutely unsinkable. Virtually indestructible.

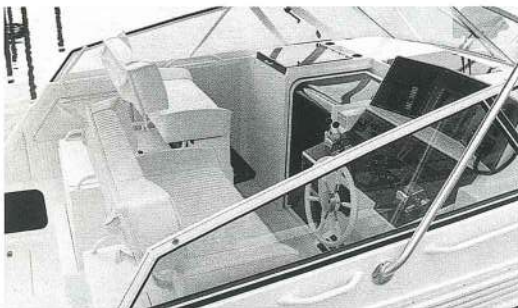

*The helm station features two 36" sliding seats, zippered storage compartments and a handy, see-through chart locker to port.*

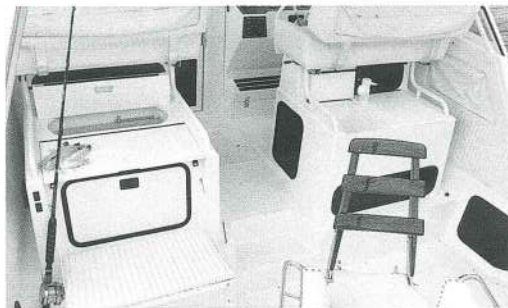

*The port workstation has an 18-gallon livewell with raw water fill, while the starboard unit has a double sink with hot and cold water.*



*The steering console hinges for quick access while the three wraparound electronics panels give you plenty of space for all your instruments.*



*The modern, contemporary interior has an open design and all white cabinets finished with real oak trim for a spacious feel.*



*The spacious galley comes with a refrigerator, alcohol electric stove and places to store everything out of the way.*

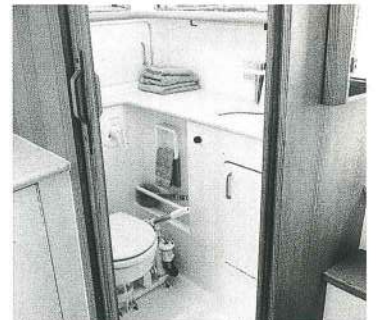

*The head features a standup shower, hot and cold running water and a tambour oak door.*



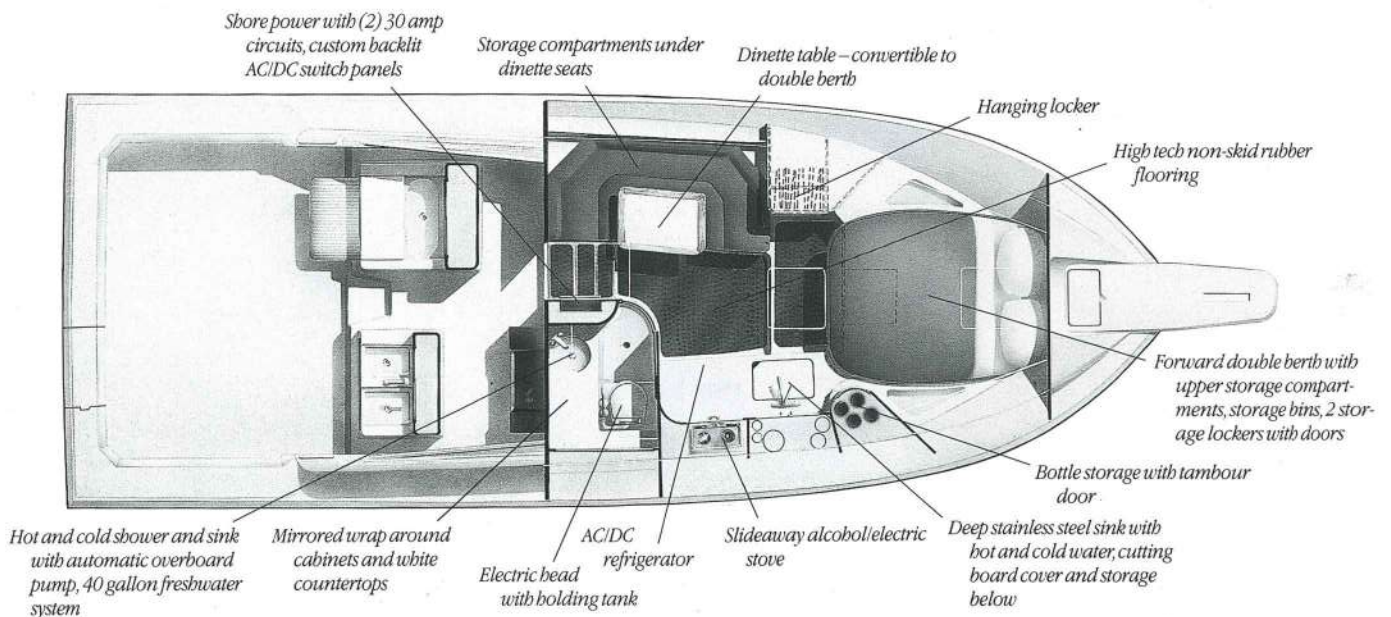
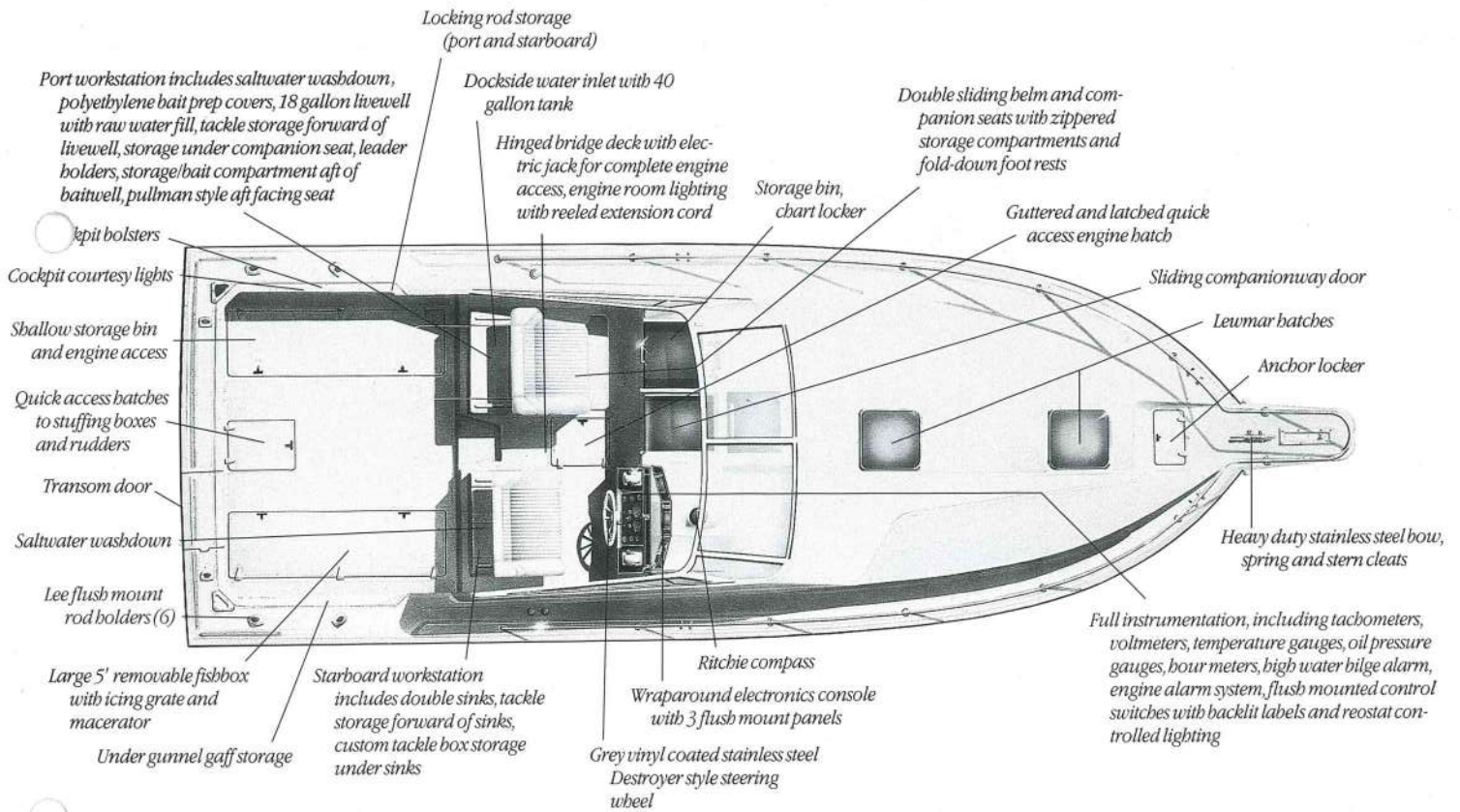
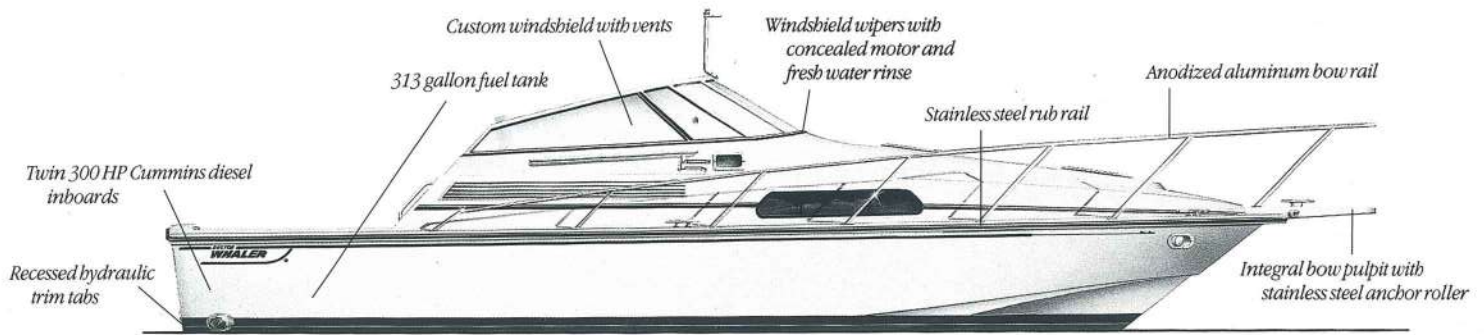



## Offshore 27

Our new Offshore 27 has just one reason for being – the pursuit of fish. Witness the fact that every bit of gear is strategically placed for easy access and fast action. The work station has removable tackle boxes, fold-down seat, and double sinks with both fresh and salt water, and a shower head. The two huge fish boxes, which have icing grates and a macerator pump, are big enough to hold just about anything reeled in over the side. And everything is contained within a deep-vee hull that's rendered absolutely unsinkable and incredibly seaworthy by our unique foam-core Unibond™ construction process.

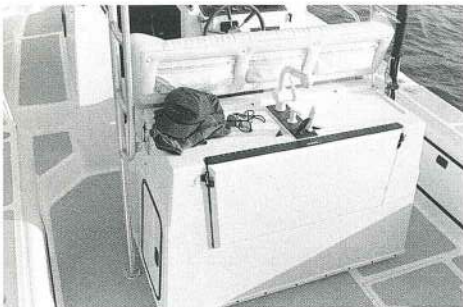
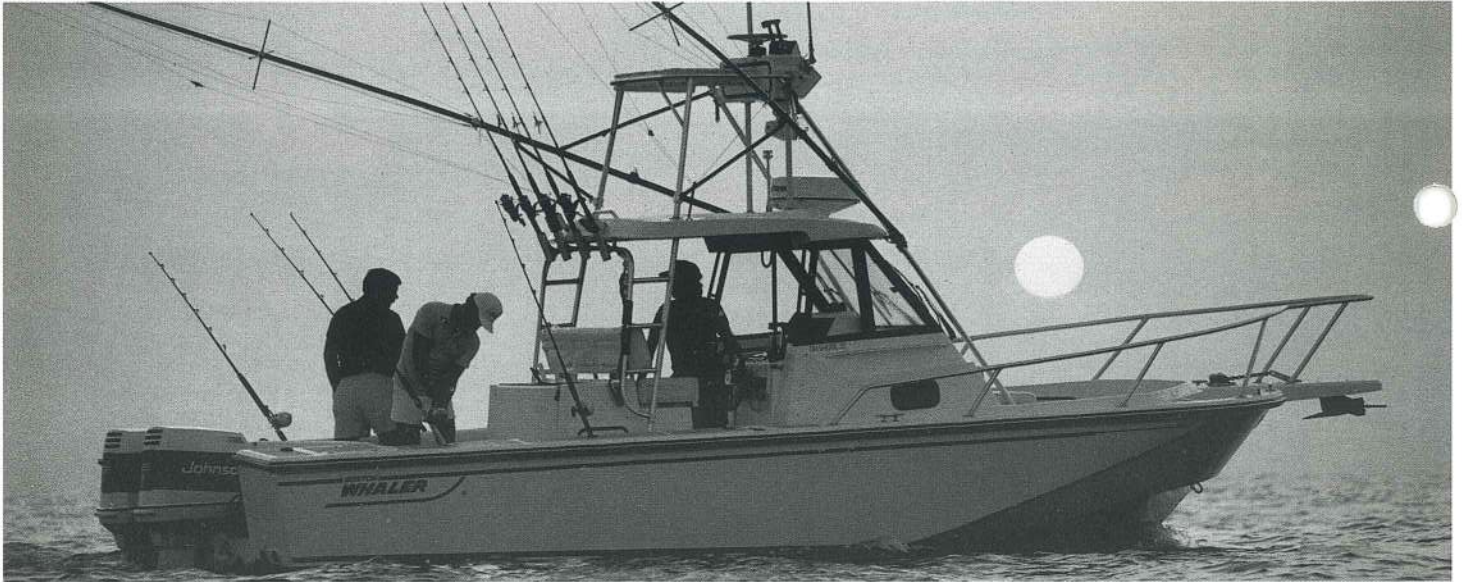

*The workstation is designed for maximum functionality, with everything from livewell to fresh or salt water within easy reach.*

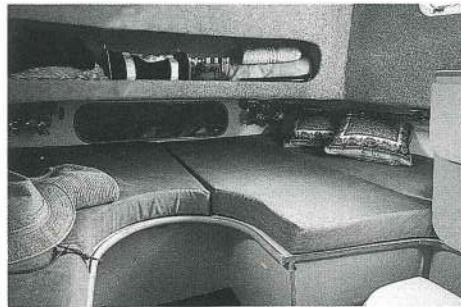

*The interior sleeps two to three and has even more storage for gear and equipment.*



*The helm station features a large surface for flushmount electronics, and it hinges for quick access to console wiring.*



*The sliding companionway hatch is designed to hold all your charts, while the "catch-all" bins are perfect for all your things.*



*There's more than enough space for all your lures in the Offshore's three removable tackle boxes.*



*The hard top has three wraparound, overhead surfaces for mounting electronics, a lighting control panel with red and white lights and overhead chart storage.*



Hardtop with aluminum legs, 3 wraparound overhead electronics mounting surfaces, aft overhead chart storage area, lighting control panel with white and red lights, forward overhead storage compartment

Mounting pad for radar and navigational antennas, molded in non-skid for optional upper station

Full height windshield with vent windows

Windshield wipers (3) with freshwater rinse

Solar cabin vent

1 1/4" aluminum bow/side rail

Spreader lights (2)

Hydraulic trim tabs

Bow pulpit with anchor roller  
Navigation lights

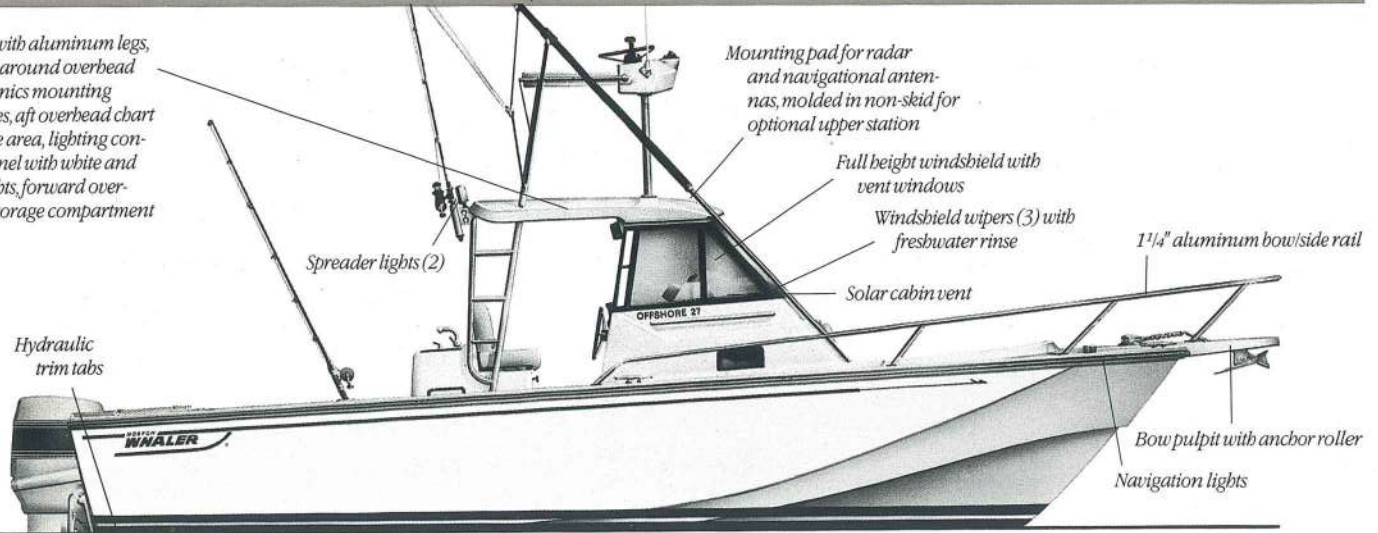

Tackle storage shelves with 3 large removable tackle boxes

2 sinks with cutting boards, fillet knife slots, shower head, detachable hose for washdown, and 30 gallon fresh water tank

Removable companionway door

Chart surface on sliding companionway hatch

Lockable under gunnel rod storage (for 6 rods total)

18 gallon livewell with raw water fill and aerator (under seat)

Drink holders (2) and 2 "catch-all" bins

Hydraulic steering

Folddown aft facing seat

Compass

Forward storage bins with lockable doors

Stainless steel cleats (stern, spring and bow)

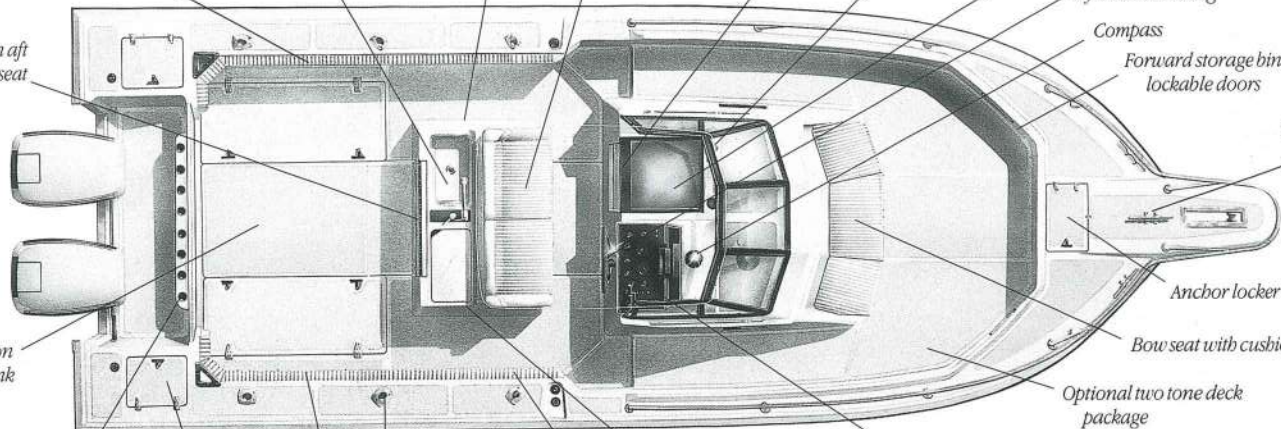

Anchor locker with hatch

Bow seat with cushions

Optional two tone deck package

243 Gallon fuel tank

Custom console switch panel with dimmer switch and back lit labels

Folddown splashwell door with 8 rocket launchers

Quarter storage bins with covers and lights

Flush mount rod holders (4 standard)

Large storage compartment with access door

Cockpit courtesy lights

Cockpit coaming pads

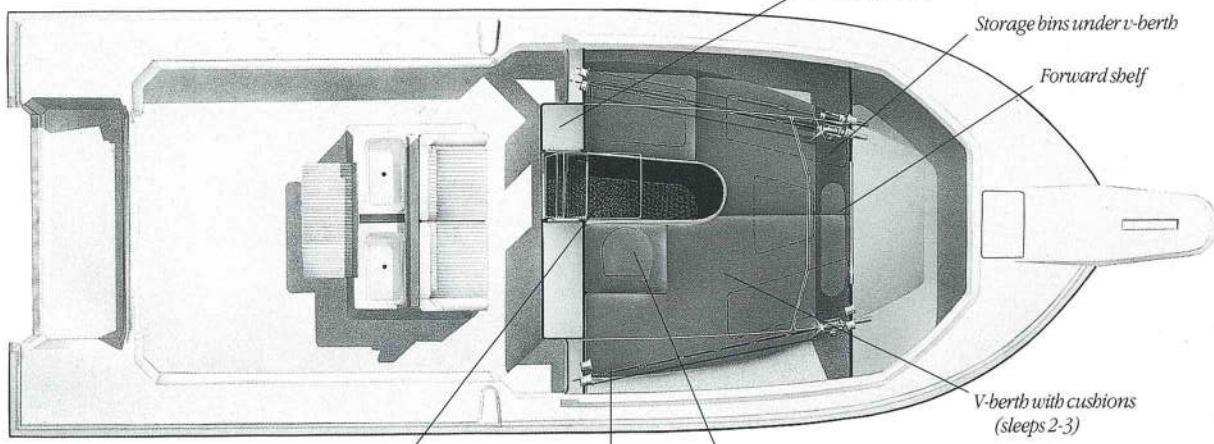

Hanging locker

Storage bins under v-berth

Forward shelf

V-berth with cushions (sleeps 2-3)

Non-skid rubber cabin sole covering

4 rod racks, port and starboard

Electric marine head with holding tank and macerator discharge pump



# Whaler 27 Walkaround

The biggest of our Walkarounds, this wide-beam Whaler is designed to have wide appeal. On deck, there's plenty of seating with the padded L-shaped companion seat, bow seat and fold-down stern seat. Below deck, there's a roomy cabin that sleeps four and includes an athwartships berth that can be accessed from the cockpit, full galley, dinette and private head. This comfort, however, doesn't come at the expense of fishing features – the 27 includes two huge fish boxes with icing grates and macerators, and a walk-through transom with a live bait well, fresh-water sink and rod holders.

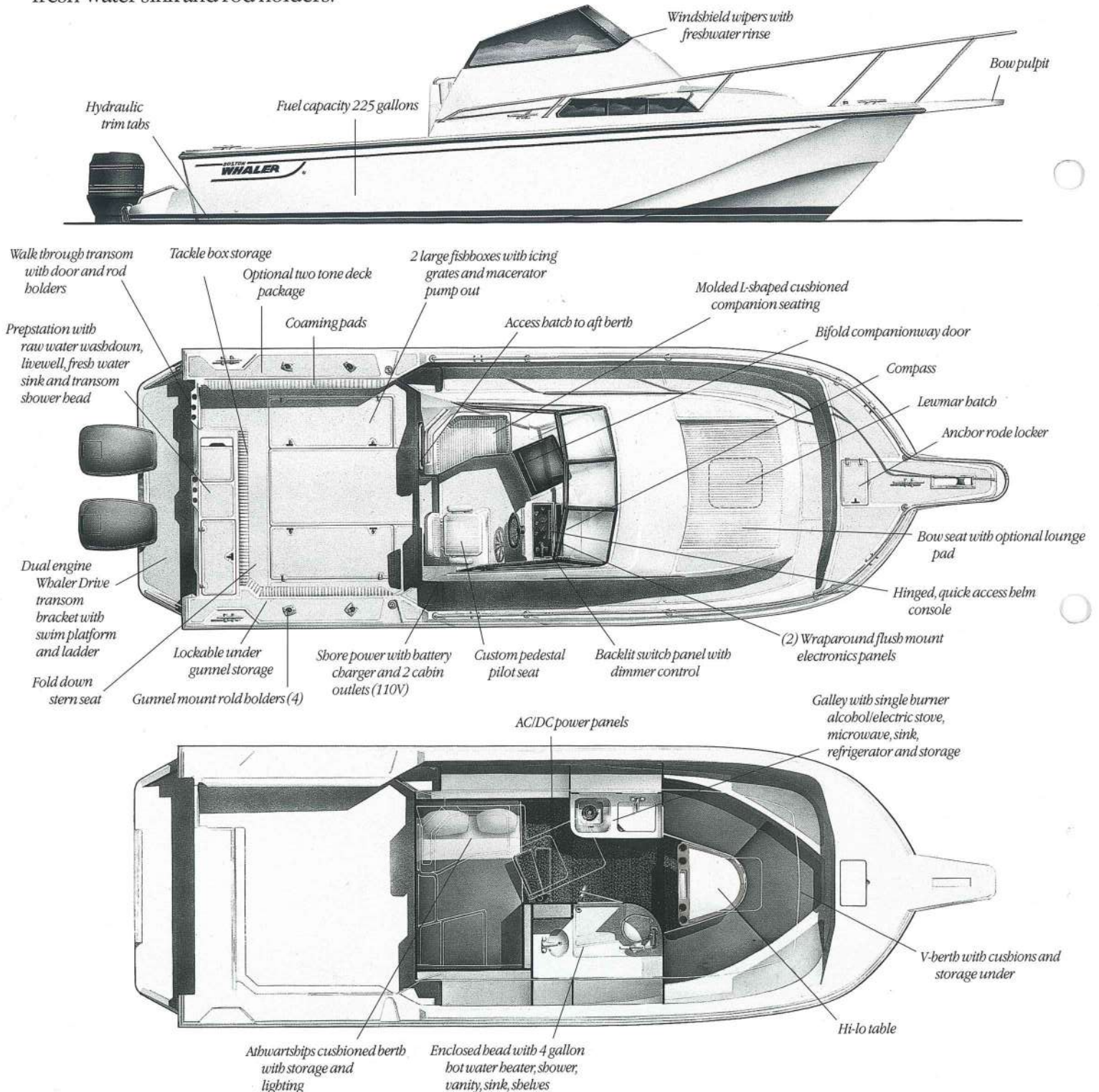



# Whaler 23 Walkaround

Presenting the 23 Walkaround, a boat for those who demand a lot out of a boat and a lot in it. The 23 offers a brand new beamy deep-vee hull that can handle the roughest of seas, yet it's still trailerable. The cabin includes not only a v-berth, but also a galley and an enclosed head, unusual to find in a boat of this size. The on-board features include fish boxes, and a walk-through transom with a fresh-water sink, live well, tackle boxes and a fold-down stern seat.

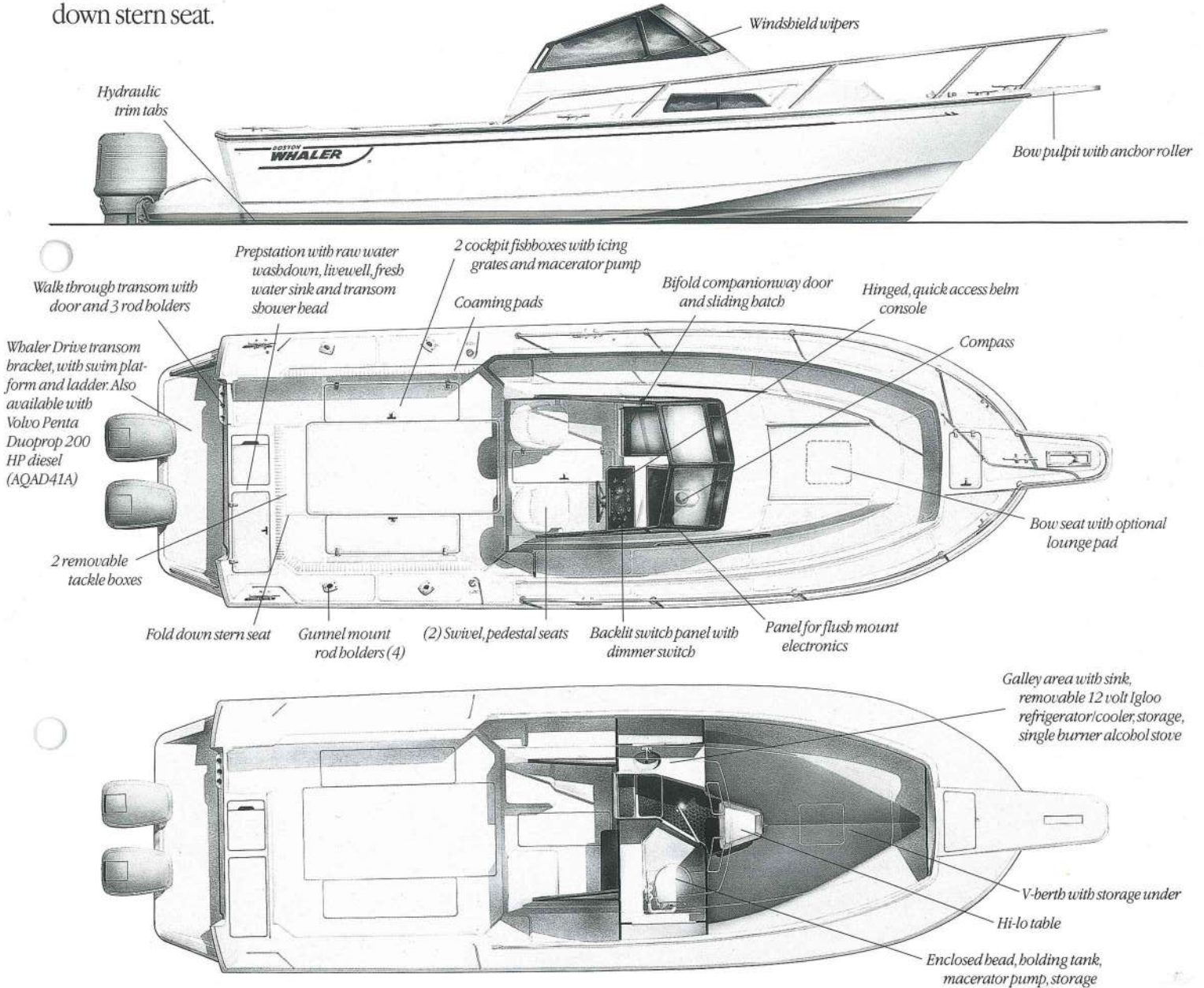

# Whaler 21 Walkaround

The smallest of our Walkarounds, the 21' has lots of room for a boat its size, and it's easily trailerable. Look for it this Spring at your Boston Whaler dealer.

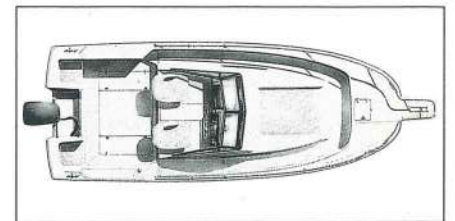



# Outrage 17

The Outrage 17 may be the smallest of our Outrage family, but don't be fooled by its size. With its deep-vee hull and 120-hp capacity, the 17 can tough it out with the big boys. Its center-console is designed with plenty of storage inside and a lockable electronics box. And its new interior gives you unobstructed fighting room from bow to stern.

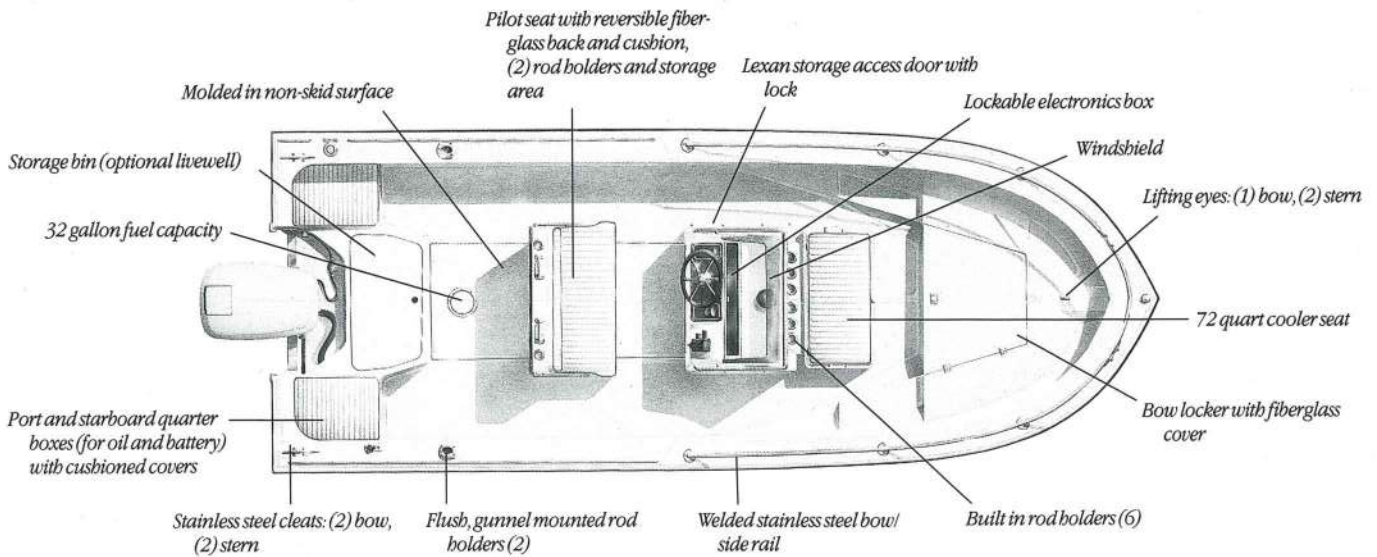

There's a covered storage bin forward of the engine that's convertible to a live well with an optional raw-water circulating kit.

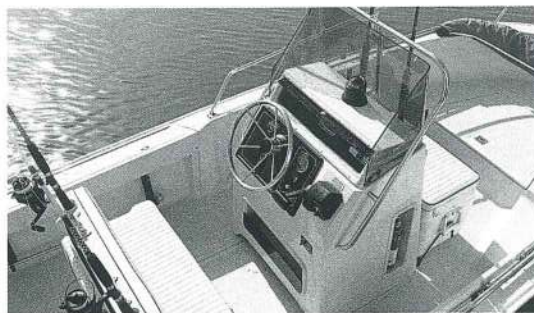

The 30" center console has a lockable electronics box, port access door to large dry storage area, stainless wheel, two instrument mounting surfaces and an aft storage bin.

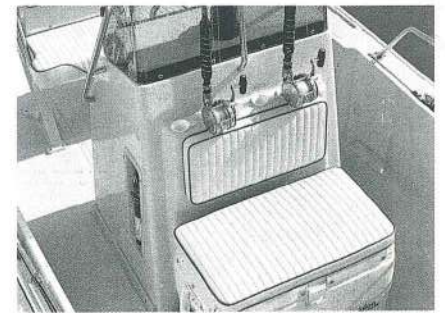

Forward of the console there are six rod holders and a big 72-quart cushioned cooler seat.



# 16 SL

After 33 years of listening to customers, we know what people want in a small boat, and our new 16 SL was designed to provide it. Outside, it has a totally new hull design, with a smooth tracking, deep-vee hull and higher freeboard. Inside, storage abounds – with built-in coolers under both forward seats, two storage bins in the aft cockpit, and a big six-foot locker in the cockpit sole. All of which means the 16 SL will take you wherever you want to go – skiing, fishing, diving, or just tooling around with friends – without cramping your style.

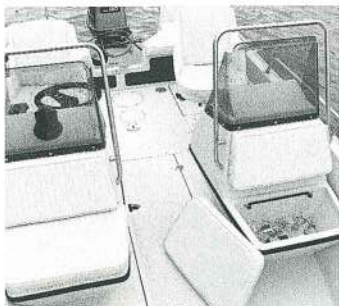
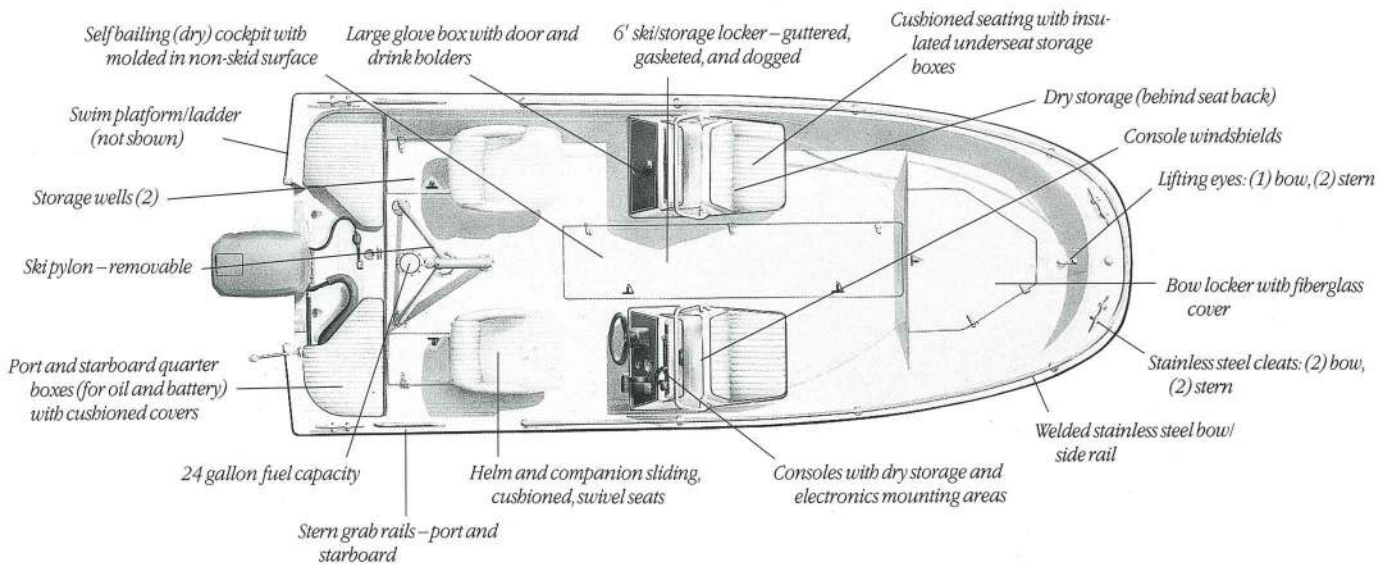

Both seats forward of the consoles are comfortably cushioned and have built-in coolers.

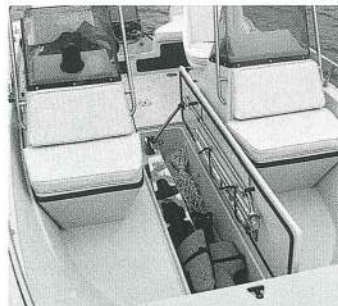

The hinged, six-foot storage locker in the cockpit sole is big enough to hold everything from skis to diving equipment.



The sporty command console is equipped with a black padded steering wheel, gauge panel and electronics mounting surface.



The port console has a fold-out table with drink holders and even more space for mounting electronics.



# The complete 1991 line

## Sport Series



*Tender 9*



*Tender 11*



*Sport 13*



*Super Sport 11*



*Super Sport 13*



*Super Sport 15*

## Center Console Series



*Montauk*



*Outrage 17*



*Outrage 22 Cuddy*

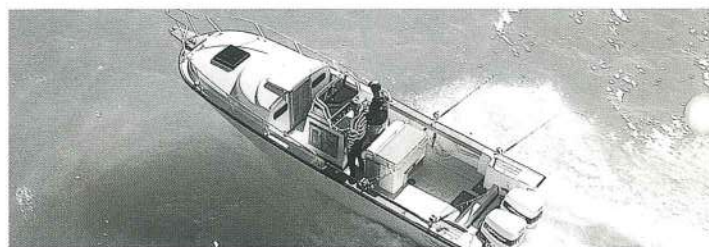

*Outrage 25 Cuddy*

## Sportfishing Series

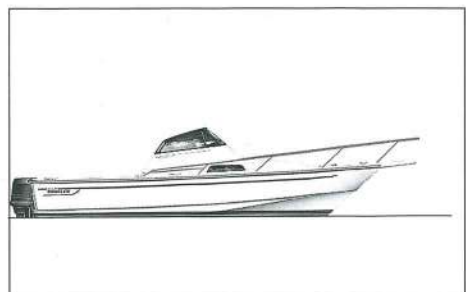

*Whaler 21 Walkaround*

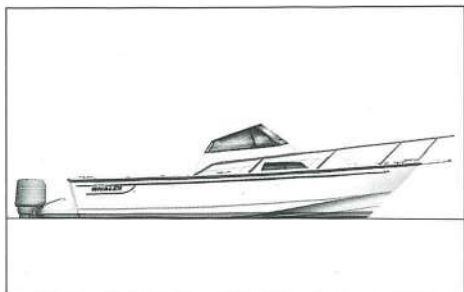

*Whaler 23 Walkaround*



*Whaler 25 Walkaround*



# from Boston Whaler.



*Sport GLS 13*

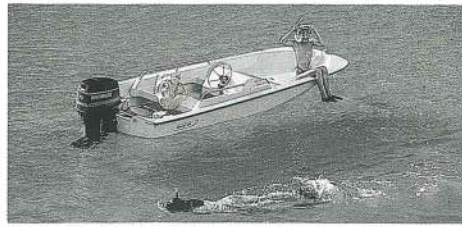

*Sport GLS 15*

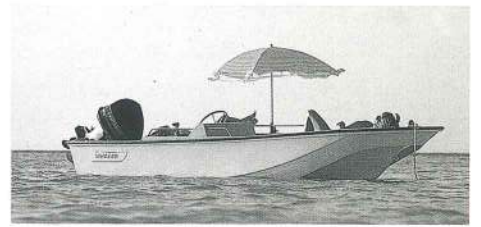

*Sport GLS 17*



*16 SL*



*Outrage 19*



*Outrage 22*

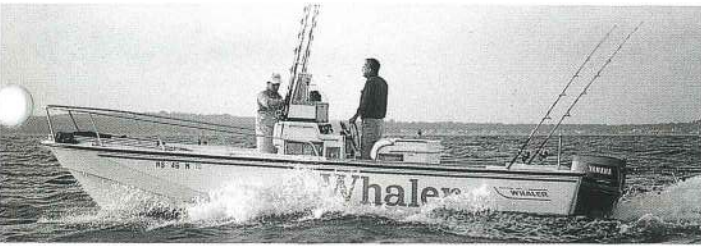

*Outrage 25*

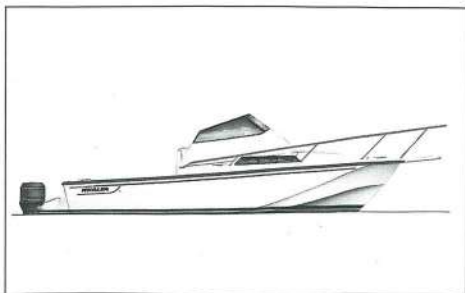

*Whaler 27 Walkaround*



*Offshore 27*

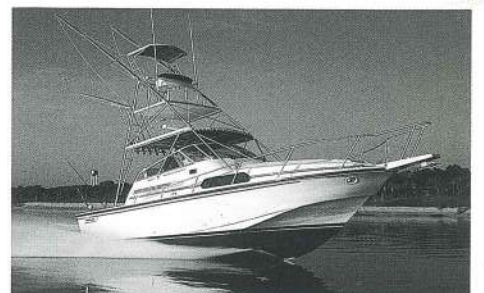

*Whaler 31L*



Sport Series	L.O.A.1	Beam	Draft2	Boat weight (lbs.) standard model1	Max. weight capacity (persons, motor & gear)3	Swamped capacity4	Persons capacity	Max. horsepower5	Min. horsepower6	Recommended engine shaft length	Standard fuel capacity (gallons)
Tender 9	9'0"	4'6"	5"	165	405	600	3	5	-	15"	-
Tender 11	11'4"	5'0"	6"	210	560	750	3	10	-	15"	-
Sport 13	13'4"	5'5"	6"	360	1200	1600	6	40	9	20"	-
Super Sport 11	11'4"	5'0"	6"	250	560	750	3	20	-	15"	-
Super Sport 13	13'4"	5'5"	6"	360	1200	1600	6	40	9	20"	-
Super Sport 15	15'3"	5'8"	8"	580	1055	1800	5	70	20	20"	-
Sport GLS 13	13'4"	5'5"	6"	360	1200	1600	6	40	9	20"	-
Sport GLS 15	15'3"	5'8"	8"	580	1055	1800	5	70	20	20"	-
Sport GLS 17	16'7"	6'2"	9"	850	1415	2000	7	100	35	20"	-
16 SL	15'6"	6'6"	10"	1025	1320	(9)	6	90	55	20"	24

### Center Console Series

Montauk	16'7"	6'2"	9"	900	1415	2000	7	100	35	20"	-
Outrage® 17	17'3"	6'8"	13"	1020	1340	1850	6	120	50	20"	32
Outrage 19	18'6"	7'2"	10"	1250	1925	3000	7	150	75	25" (7)	63
Outrage 22 outboard	22'3"	7'5"	14"	2050	2655	5000	11	240	90	25" (7)	77
Outrage 22 Whaler Drive™	24'2"	7'5"	14"	2300	2655	5000	11	300	90	25" (8)	77
Outrage 25 outboard	24'7"	8'0"	16"	3300	3035	9000	12	300	115	25" (7)	140
Outrage 25 Whaler Drive	26'6"	8'0"	16"	3550	3035	9000	12	450	115	25" (8)	140
Outrage 22 Cuddy outboard	22'3"	7'5"	14"	2250	2655	5000	11	240	90	25" (7)	77
Outrage 22 Cuddy WD	24'2"	7'5"	14"	2500	2655	5000	11	300	90	25" (8)	77
Outrage 25 Cuddy WD	26'6"	8'0"	16"	3750	3035	9000	12	450	115	25" (8)	140

### Sportfishing Series

Whaler® 21 Walkaround	21'0"	8'6"	13"	1800	2550	(9)	11	250	(9)	25"	95 (11)
Whaler 23 Walkaround	26'4"	8'6"	17"	2650	2595	(9)	12	400	(9)	25" (10)	180 (11)
Whaler 25 Walkaround	27'11"	9'6"	18"	4600	4200	10000	12	550	300	25" (12)	250
Whaler 27 Walkaround	29'1"	10'0"	21"	5850	4200	10000	12	600	300	25" (12)	225
Offshore 27	26'7"	10'0"	21"	5800	4200	10000	12	600	300	25" (12)	243
Whaler 31 L	31'9"	11'10"	34"	12500	4200	NA	12	-inboard-			313

(1) L.O.A. and boat weight include Whaler Drive unit on all Whaler Drive models. Does not include bow pulpit, where applicable.

(2) Draft for outboard models with engine(s) tilted clear of water. May vary slightly depending on load and engine size.

(3) BIA and U.S. Coast Guard Standards. Whaler 31 L persons and gear only.

(4) Total weight (persons, motor and gear) boat will support if filled with water.

(5) V-8 engines are not compatible with standard 22'-27' Whaler Drive models. 27' Whaler Drive models will accept twin V-8 engines with the optional V-8 Whaler Drive.

(6) Minimum horsepower to plane satisfactorily with light load.

(7) 25" engine shaft for single installations and 20" engine shaft for dual installations.

(8) Requires 25" shaft length for single or dual engine installation.

(9) Information not available at time of printing—see your dealer.

(10) 30" engine shaft for single installations and 25" for dual installations.

(11) Preliminary design estimates. Actual figure may vary slightly.

(12) Requires dual engines with 25" shaft length.

株式会社マツイ  
 東京都港区麻布台2丁目4番7号  
 TEL 03-586-4141



1149 Hingham Street, Rockland, MA 02370  
 (617) 871-1400  
 FAX (617) 878-7242  
 Telex No. 940-0708

Specifications and standard equipment subject to change.  
 BOSTON WHALER®, Whaler Drive™, Outrage®, Whaler®, Unibond™ and the Boston Whaler logo are trademarks and registered trademarks.  
 © 1991 Boston Whaler, Inc. All rights reserved.