

# Boston Whaler®

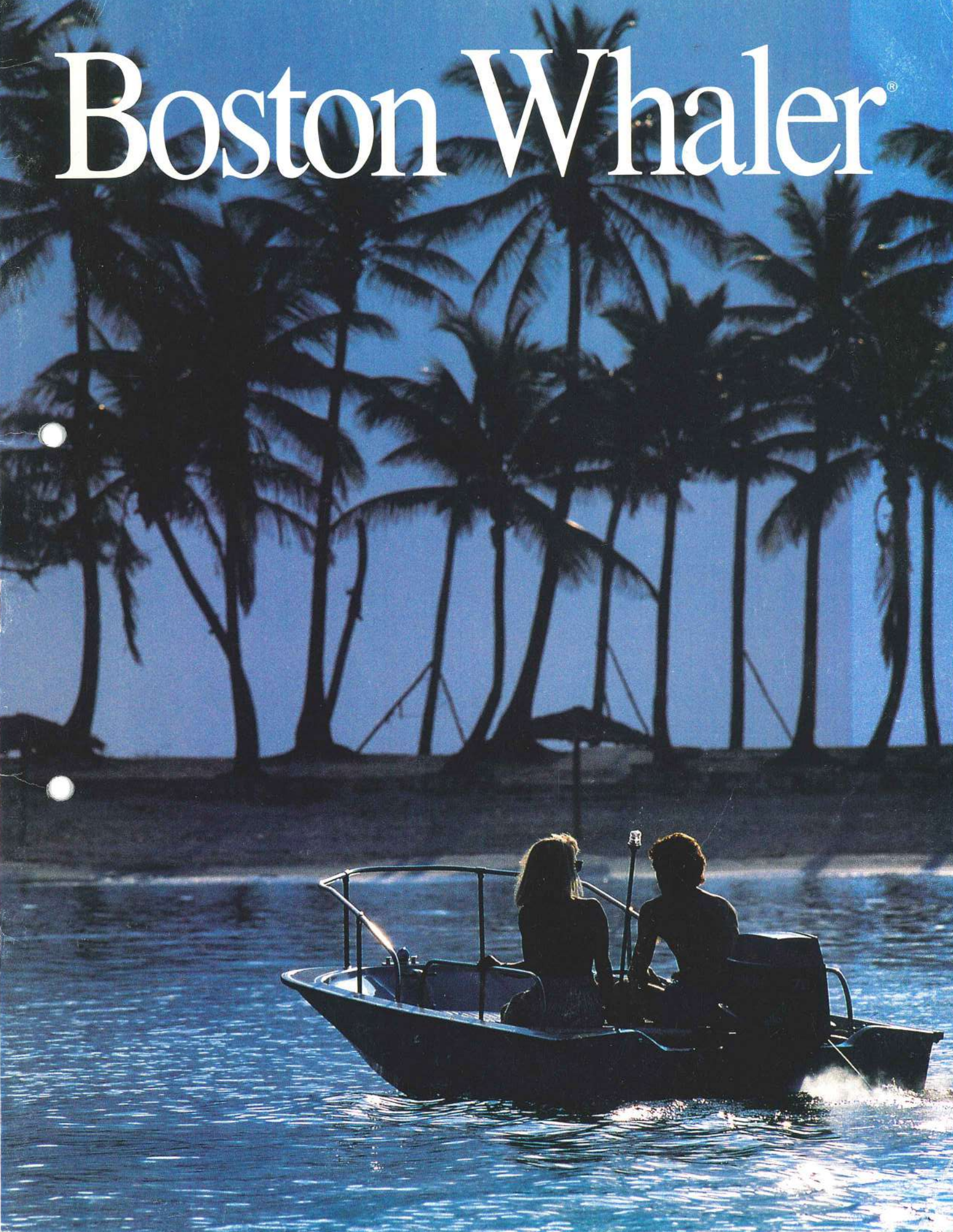



For over 30 years, we've been going to extremes to demonstrate the unsinkable foam-core construction of every Boston Whaler.



You can pack up to 1,600 pounds into a 13' Boston Whaler; then pull the plug, and it'll float high enough to keep the engine dry.



## Nobody builds a boat like Boston Whaler.

And nobody goes to such extremes to prove their point. The fact is, a Boston Whaler absolutely, positively will not sink. Period.

The reason for such phenomenal buoyancy lies in the way we construct every Boston Whaler hull. It's a process totally unlike any other.

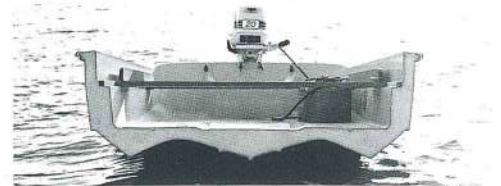

First, we mold an inner and outer skin of fiberglass. Then, before these have a chance to cure completely, we join them together and inject foam into the cavity between. The foam expands rapidly to fill the entire structure from gunnel to gunnel, then bonds with the uncured fiberglass to form a solid, one-piece hull. This rapid expansion creates an incredibly tight-celled material, impervious to water, and able to provide two and one-half times the floatation required to meet U.S. Coast Guard specifications.

The one-piece structure that results also adds unbelievable strength and rigidity to every Boston Whaler. A feature you're sure to appreciate when dodging big offshore rollers or crossing angry harbor bars.

Boston Whaler construction is something you'll appreciate if and when you decide to sell your boat, too. Because we build our boats to withstand the forces of the marketplace just as effectively as they resist the forces of nature. In other words, Boston Whalers hold their value. And that's reason enough to pay a little bit more for one.



Boston Whaler founder, Dick Fisher, invented the first unsinkable Whaler in 1958. And he proved his claim in this Life Magazine photo.

Of course, before you decide to spend your hard-earned money on a boat, you should also consider the fact that Boston Whalers are backed by one of the best hull warranties in the business. It lasts for ten full years no matter how many owners put their trust in the boat.

Boston Whaler. Unsinkable. Unbeatable. For over 30 years.



## Distinctive shapes for demanding jobs.

Although we've inspired many imitators, the Boston Whaler hull remains as unique on the outside as it is on the inside. That's because safety is our first and foremost consideration whenever we set out to design a new boat. Whether that means keeping kids safe while they're zipping around the harbor, or keeping fishermen secure when they head offshore.



Twin sponsons accomplish the former assignment admirably. Found on smaller Whalers, they act to keep our boats incredibly stable, even when confronted by a throng of thirteen-year-olds. They also provide unmatched load-carrying capacity. Which means you can pack one of our smaller boats chock full of fishing gear, groceries, diving equipment – you name it – and not have to worry about taking an unexpected swim.

As Whalers get larger, however, their hulls become perfectly suited for the most vigorous offshore work you'll ever ask a boat to do. Sharper bow angles tear cleanly through the water, while curved chines flick spray out, back and away from you and your passengers. Wider beams give you the sure-footed stability you need. And deep-Vees, with up to an 18-degree deadrise, make for a fast, comfortable trip.



As you can see, Boston Whalers are shaped the way they are for a purpose – to be the safest, strongest, most reliable boats afloat.

If you're seriously considering a boat, now is the time to think about what you'll demand from one. And now is the time to consider one of the Boston Whalers described on the following pages.

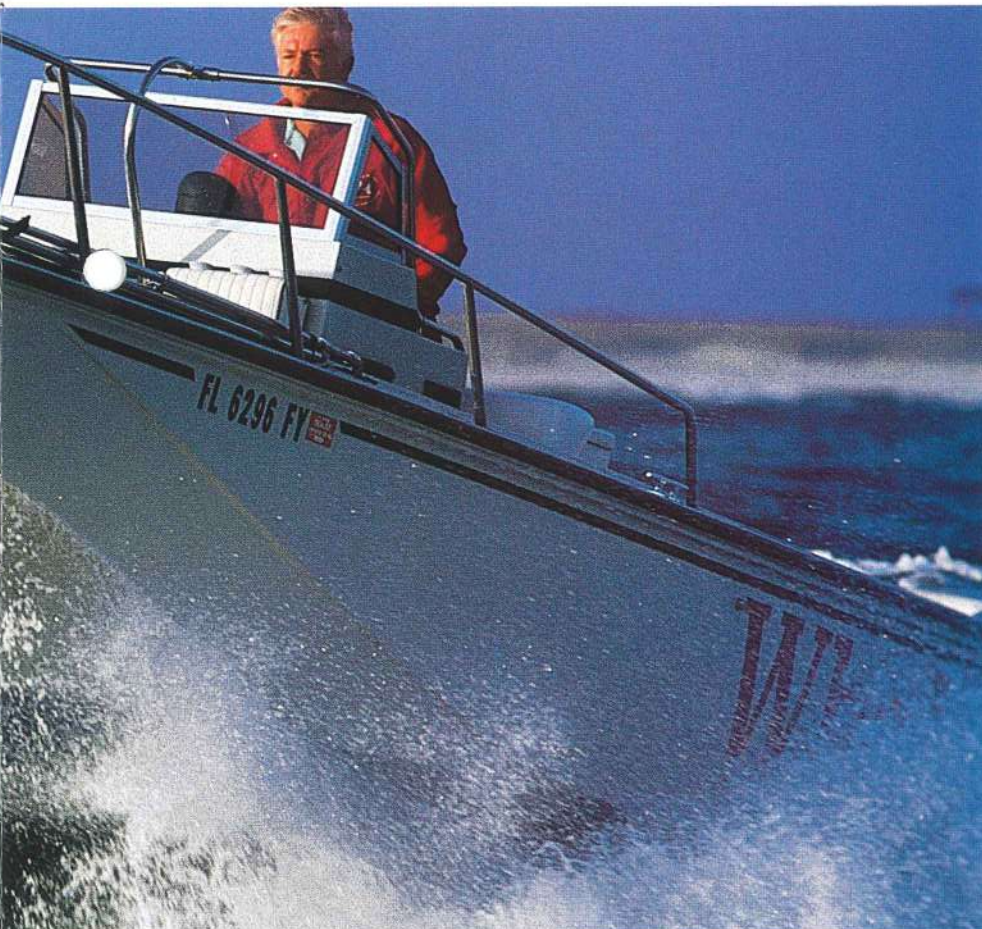





## Hard-working people need a hard-working boat.

It should come as no surprise that Boston Whalers are used extensively by government agencies, commercial corporations and small businesses all over the world. From the United States Coast Guard to rental fleets and boat yards.



It's a testimony to the strength, reliability and unrivaled performance you can expect from every Boston Whaler.

Our Custom Boat Division starts with the same basic hulls available to people like you, then fits them out especially for the jobs they're meant to do. Search and Rescue. Fire Prevention. Marine patrol. The list goes on.



You can take comfort in this fact if and when you decide to invest in a Boston Whaler. But even if you don't, you can take comfort in the fact that Boston Whalers are out there, patrolling your local waters, and available to lend a hand should you ever get into trouble.



Sport Series.  
Up to almost anything,  
almost anywhere.





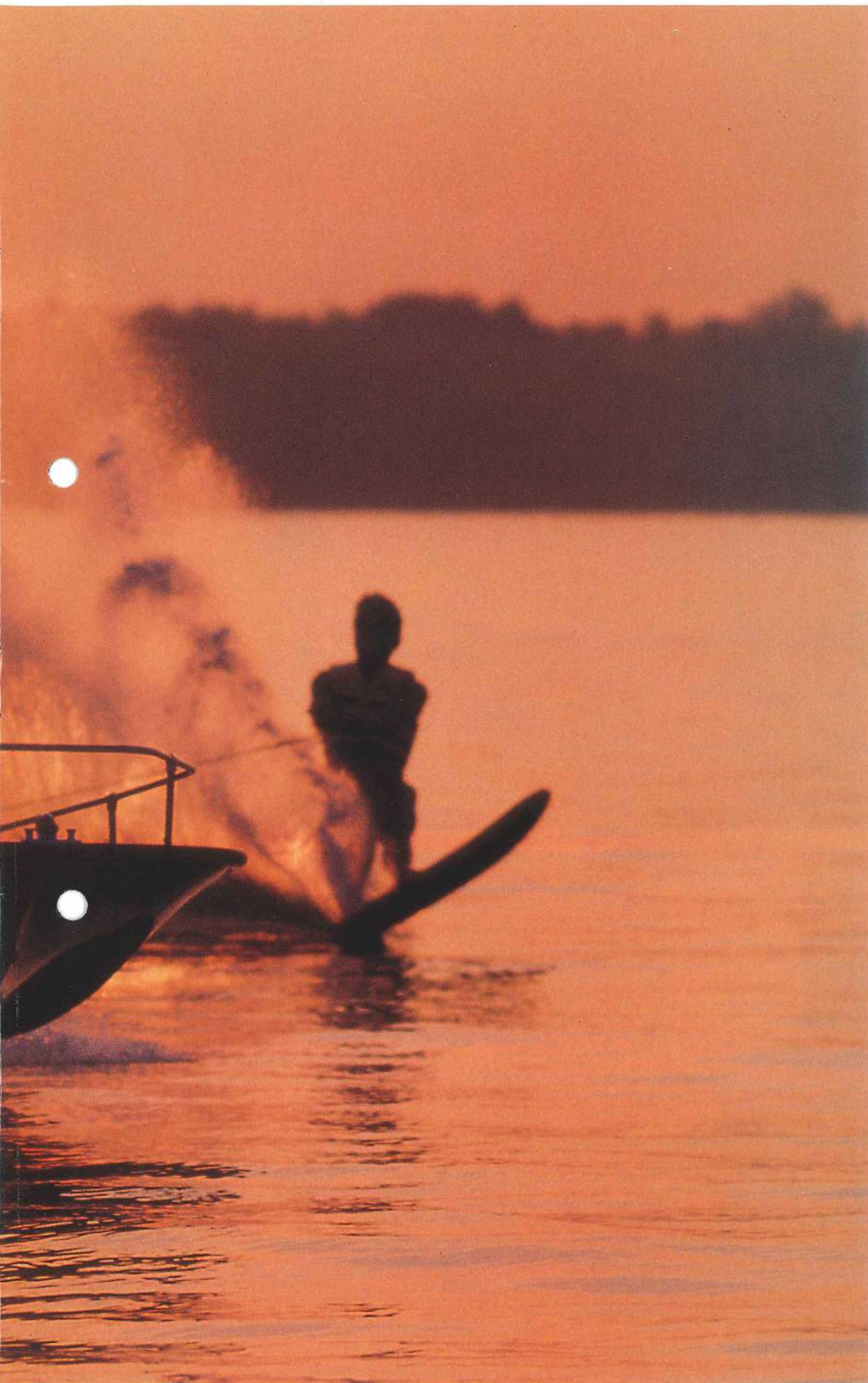

“If you ask me, that Whaler is safe. Our kids practically grew up in it, and I never once had any reservations about them taking it out alone.”



Our rugged Tender 9 takes up to a five horsepower motor.



People who own fine yachts don't need to compromise on their tenders. And they don't – Tender 11.



**Tender 9**  
Standard features include: Mahogany bow locker cover • Bow eye with lifting eye • Bow norman tie-up pin • Molded-in oarlock sockets • Mahogany thwart seat • Heavy-duty rub rail • Drain plug • Pair of ski/lifting eyes.

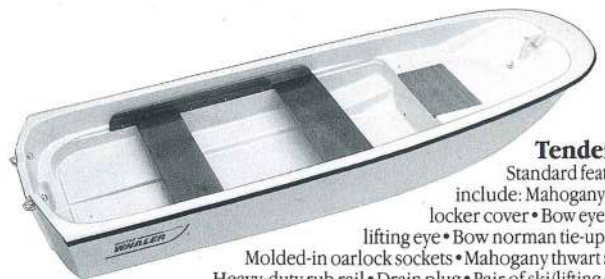

**Tender 11**  
Standard features include: Mahogany bow locker cover • Bow eye with lifting eye • Bow norman tie-up pin • Molded-in oarlock sockets • Mahogany thwart seat • Heavy-duty rub rail • Drain plug • Pair of ski/lifting eyes.



Anyone whose childhood memories include the sights and sounds of the American waterfront will have experienced our Sport in one form or another. After all, it's been a part of this environment for over 30 years.

For many, the Sport will inspire fond recollections of taking the helm for the very first time, with a boatload of friends and the whole summer to look forward to. Others will remember admiring the Sport from afar, a neat little boat that seemed to go just about anywhere, do just about anything and satisfy just about everyone.

That would include adults, by the way. Parents have always known they could rely on the Sport's unsinkable cathedral hull to bring the boys home safely. While working people could depend on its unmatched load-carrying capacity to help get the job done.

The Sport. A classic example of what a great boat should be.

## Sport



The Sport 13. Over 30 years old, but still a kid at heart.



A secluded beach, swaying palms, sunshine, clear water and the Sport 15.



**Sport 13**  
Standard features include: Mahogany bow locker cover • Bow eye with lifting eye • Bow norman tie-up pin • Mahogany side steering console with stainless wheel and mechanical steering • Two mahogany thwart seats • Heavy-duty rub rail • Drain plug • Battery box kit • Pair of ski/lifting eyes.



**Sport 15**  
Standard features include: Mahogany bow locker cover • Bow eye with lifting eye • Bow chock • Bow norman tie-up pin • Mahogany side steering console with stainless wheel and mechanical steering • Two mahogany thwart seats • Stainless side rails • Heavy-duty rub rail • Navigation lights • Drain plug • Battery box kit • Pair of ski/lifting eyes.



The Super Sport 11 is a hard-working tender.



The Super Sport 13 can take up to a 40 horsepower engine. Which means it can take you where you need to go in no time.

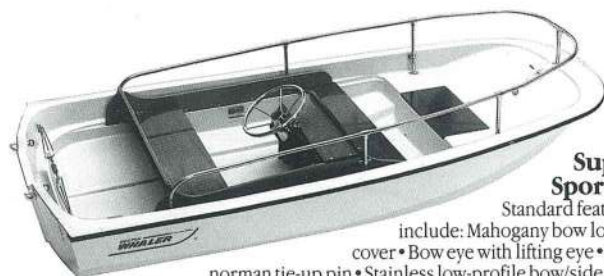

**Super Sport 11**

Standard features include: Mahogany bow locker cover • Bow eye with lifting eye • Bow norman tie-up pin • Stainless low-profile bow/side rail • Mahogany console with stainless steering wheel • Two mahogany thwart seats • Heavy-duty rub rail • Drain plug • Pair of ski/lifting eyes.



**Super Sport 13**

Standard features include: Mahogany bow locker cover • Bow eye with lifting eye • Bow chock • Bow norman tie-up pin • Stainless low-profile bow/side rail • Mahogany console with stainless steering wheel • Two mahogany thwart seats • Aft seat storage • Heavy-duty rub rail • Navigation lights • Drain plug • Battery box kit • Pair of ski/lifting eyes.



**H**ow do you follow up on a boat that's become a classic? You can begin by adding a larger, sportier console, a hinged storage locker aft, a low-profile bow/side rail, and solid mahogany seat backs. What you end up with is the Super Sport.

Just as fast, just as dependable, just as stable as its predecessor, the Super Sport will get you there and back with just a bit more pizzazz.

Pull up to some deserted stretch of sand and enjoy a day at the beach away from the crowds. Tear off to your favorite fishing hole on a lazy afternoon. Clip on the tow rope and put some mileage under your skis.

Of course, the Super Sport has the same twin-sponson hull as the Sport, with the same core of closed-cell foam. So it's absolutely unsinkable and rugged beyond belief.

The Super Sport. It's one super Boston Whaler.

## Super Sport



The Super Sport 15 is fast, safe and incredibly stable. The kind of performance you can expect from every Boston Whaler.



Chasing fun or chasing fish, it's all in the line of duty for the Super Sport 15.



### Super Sport 15

Standard features include: Mahogany bow locker cover • Bow eye with lifting eye • Bow chock • Bow norman tie-up pin • Mahogany side steering console with stainless wheel • Two mahogany thwart seats • Aft seat storage • Stainless low-profile bow/side rail • Heavy-duty rub rail • Navigation lights • Drain plug • Battery box kit • Pair of ski/lifting eyes.



The Sport GLS 13 can take you where you need to go quickly and, above all, safely.



Two friends bone fishing on a lazy afternoon. The perfect setting for the Sport GLS 13.



**Sport GLS 13**

- Standard features include:
- Fiberglass bow locker cover
  - Bow eye with lifting eye
  - Bow norman tie-up pin
  - Fiberglass seats
  - Console with side storage box
  - Mechanical steering with stainless wheel
  - Stainless low-profile side rails
  - Heavy-duty rub rail
  - Battery box kit
  - Pair of ski/lifting eyes.

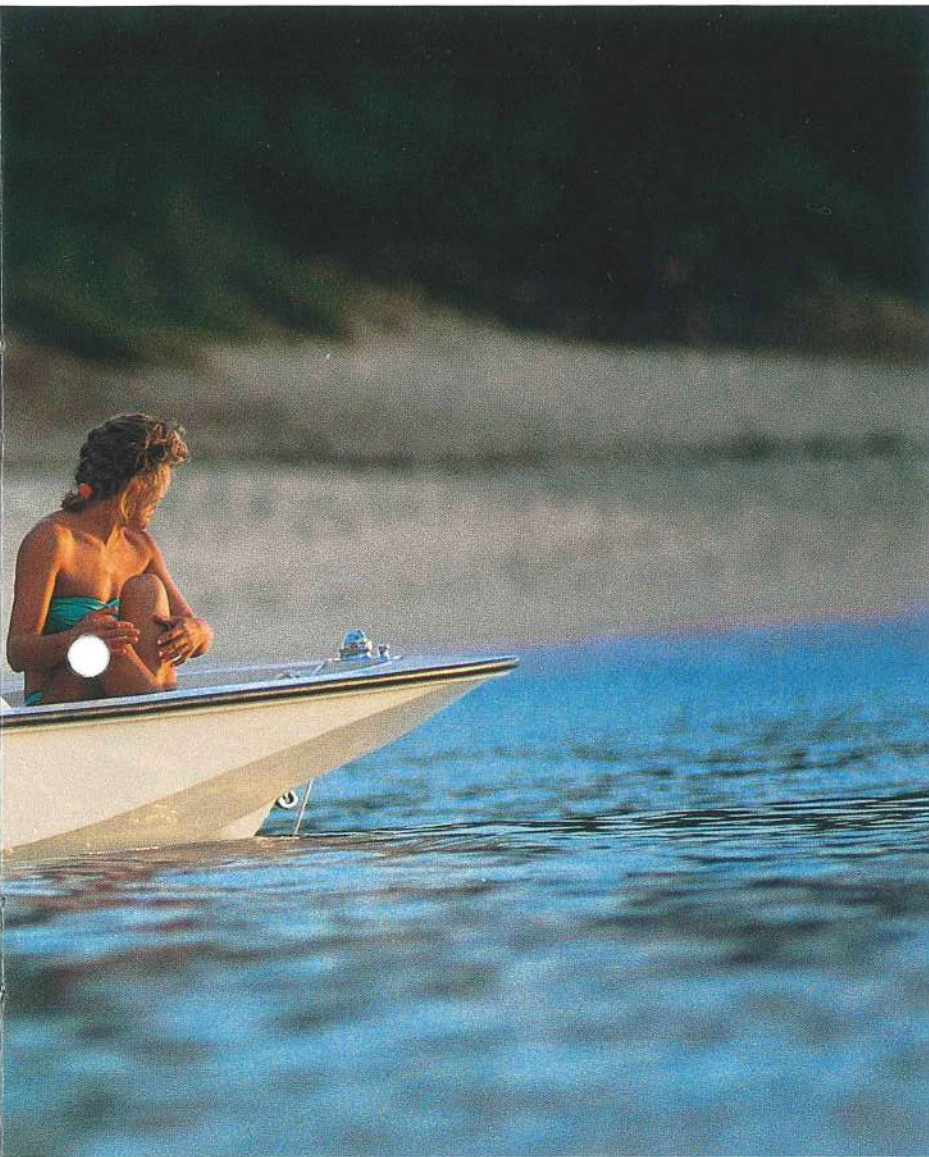

**W**e cut back on a few things when we introduced the Sport GLS – sanding, scraping, stripping and varnishing.

You won't find a stick of wood anywhere on the boat. Its hatch, console, and seats are all of tough, low-maintenance fiberglass.

What you will find, however, is unbeatable Boston Whaler performance. Like enough load-carrying capacity to make the Sport GLS ideal for hard-working people who need a hard-working boat. And enough stability to make it the kind of boat both parents and kids can agree on.

It's all made possible by a cathedral hull filled from gunnel to gunnel with a solid core of closed-cell foam. Making it positively unsinkable – a prerequisite if any boat is to call itself a Whaler.

The Sport GLS. Leave the sandpaper in your workshop and put it to work for you.

## Sport GLS



There's more than enough room aboard the Sport GLS 15 for you and all your gear.



Divers love the incredible stability and load-carrying capacity of the Sport GLS 15.



### Sport GLS 15

Standard features include:

- Fiberglass bow locker cover • Bow eye with lifting eye • Bow chock • Bow norman tie-up pin • Fiberglass seats • Console with side storage box • Mechanical steering with stainless wheel
- Stainless low-profile side rails • Heavy-duty rub rail • Navigation lights with switch and fuse • Battery box kit • Pair of ski/lifting eyes.

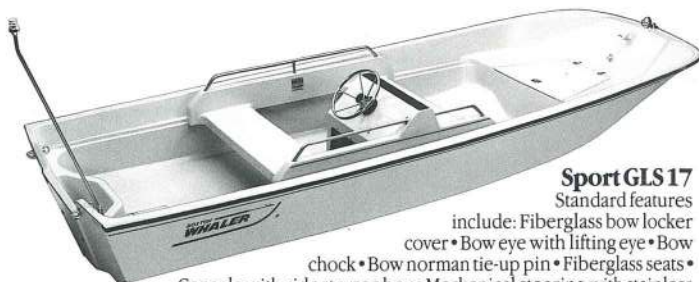

### Sport GLS 17

Standard features include:

- Fiberglass bow locker cover • Bow eye with lifting eye • Bow chock • Bow norman tie-up pin • Fiberglass seats • Console with side storage box • Mechanical steering with stainless wheel • Stainless low-profile side rails • Heavy-duty rub rail • Navigation lights with switch and fuse • Battery box kit • Pair of ski/lifting eyes.



The Super Sport Limited 15 has an interior that offers plenty of storage space, and plenty of comfort.



The Super Sport Limited 15 loves life in the fast lane.

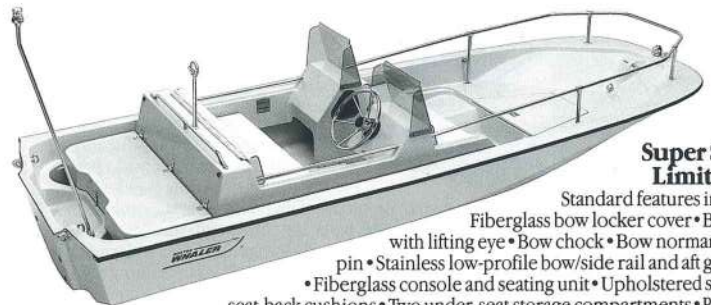

**Super Sport Limited 15**

- Standard features include:
- Fiberglass bow locker cover • Bow eye with lifting eye • Bow chock • Bow norman tie-up pin • Stainless low-profile bow/side rail and aft grab rail
  - Fiberglass console and seating unit • Upholstered seat and seat-back cushions • Two under-seat storage compartments • Port box storage bin • Mechanical steering with stainless wheel • Plexiglass windshields
  - Heavy-duty rub rail • International navigation lights • Aft seat-back storage compartment
  - Stern deck • Ski pylon • Drain plug • Battery box kit • Pair of ski/lifting eyes.



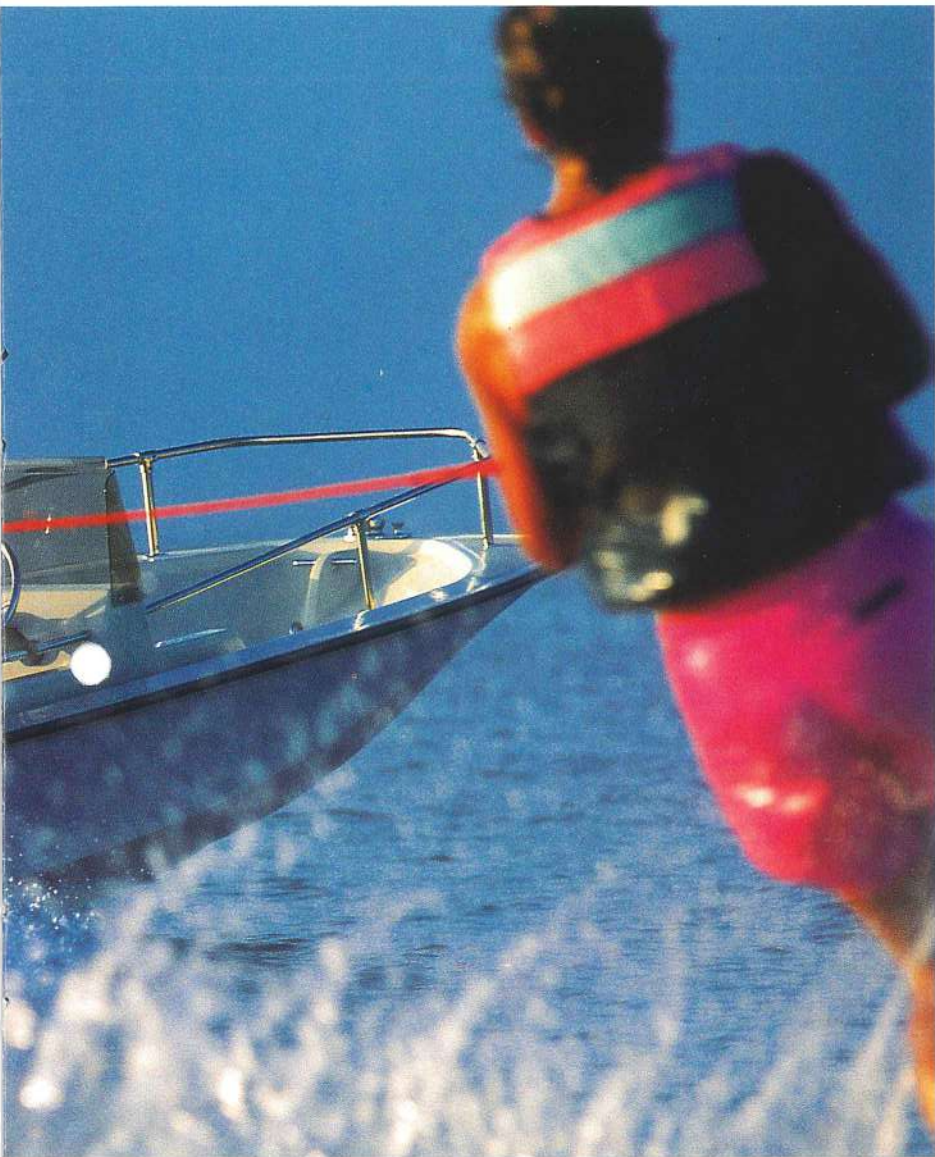

**T**here's virtually no limit to what you can do with the Super Sport Limited. Its interior is comfortable enough for just relaxing and enjoying the sunshine; its exterior is tough enough to go just about anywhere.

Both the seats and seat backs are fully cushioned and upholstered. A luxury you and all your passengers will appreciate after a long day of skiing, picnicking or just cutting loose.

Storage space abounds. The seats lift up to make room for gear and supplies. And the lockable stern deck platform gives you a place to stow your battery, fuel and oil safely out of the way.

In fact, about the only thing limited with the Super Sport Limited is maintenance. To clean, simply open the drain plug and rinse down the all-fiberglass interior.

The Super Sport Limited. All the comforts you want, all the features you need.

## Super Sport Limited



With up to a 100 horsepower engine, pulling skiers is child's play for the Super Sport Limited 17.



The Super Sport Limited 17 was designed with skiers in mind. It comes with a ski pylon, stern deck and plenty of horsepower.

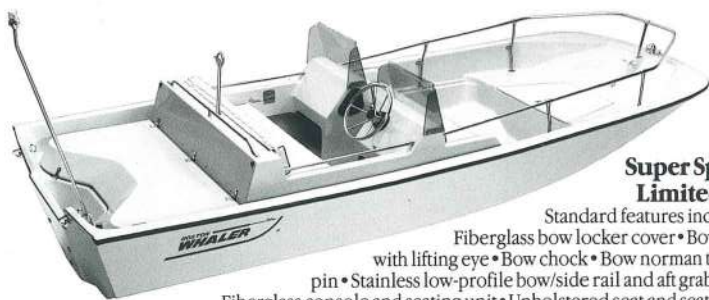

### **Super Sport Limited 17**

- Standard features include:
- Fiberglass bow locker cover • Bow eye with lifting eye • Bow chock • Bow norman tie-up pin • Stainless low-profile bow/side rail and aft grab rail • Fiberglass console and seating unit • Upholstered seat and seat-back cushions • Two under-seat storage compartments • Port box storage bin • Mechanical steering with stainless wheel • Plexiglass windshields • Heavy-duty rub rail • International navigation lights • Aft seat-back storage compartment • Stern deck • Ski pylon • Drain plug • Battery box kit • Pair of ski/lifting eyes.



The forward bucket seats are placed low in the Newport, so kids are safe and your vision unobstructed.

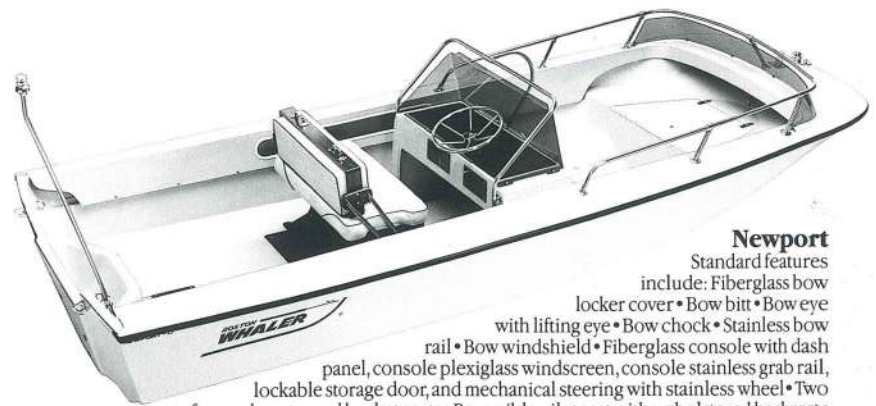

**Newport**

Standard features include: Fiberglass bow locker cover • Bow bitt • Bow eye with lifting eye • Bow chock • Stainless bow rail • Bow windshield • Fiberglass console with dash panel, console plexiglass windscreen, console stainless grab rail, lockable storage door, and mechanical steering with stainless wheel • Two forward contoured bucket seats • Reversible pilot seat with upholstered backrest • Heavy-duty rub rail • International navigation lights • Drain plug • Battery box kit • Gas tank mats and restraints, and hawsepipe • Pair of ski/lifting eyes.



The sportiest of the Sports, Newport and Mischief™ were designed to turn heads.

Newport comes fitted out with contoured bucket seats, plexiglass wind-screens and an all-fiberglass console. The pilot seat converts into a neat little fishing chair, and is large enough to seat two adults comfortably.

Mischief, on the other hand, is an all-out, fun-in-the-sun boat that more than lives up to its name. Sharp and sexy, it's designed for towing skiers or simply tearing up the water. Mischief comes with sliding bucket seats, tilt racing wheel, boarding ladder and plenty of under-deck storage for skis, gear or a picnic lunch.

Most importantly, Newport and Mischief are Boston Whalers. Which means they're not only fun, they're safe, stable and absolutely unsinkable.

Newport and Mischief. For people who take fun seriously. From a company that takes boating seriously – Boston Whaler.

## Newport and Mischief



Mischief. It's fun, fast and incredibly good-looking.

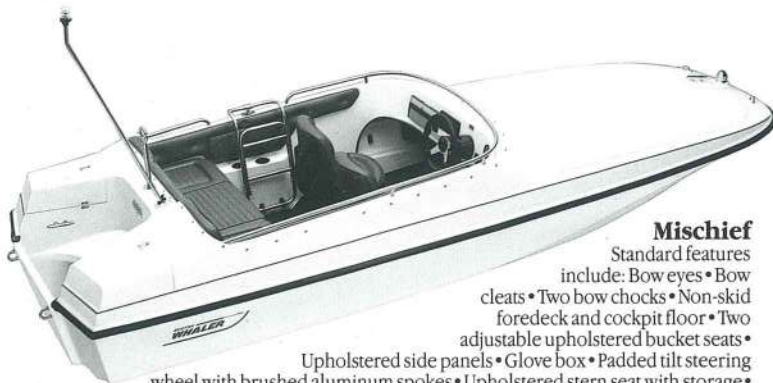

### Mischief

Standard features include: Bow eyes • Bow cleats • Two bow chocks • Non-skid foredeck and cockpit floor • Two adjustable upholstered bucket seats • Upholstered side panels • Glove box • Padded tilt steering wheel with brushed aluminum spokes • Upholstered stern seat with storage • Wraparound cockpit rail • Cockpit drink holders • Pivoting ski/boarding ladder • Ski pylon • Stern lifting eyes • Navigation lights • Removable storage compartments (aft, port and starboard) • Bilge pump with manual/automatic switch • Modular wiring harness • Two tank mats • Deck pin striping.

Center Console Series.  
Only the fish have more fighting  
room than this.

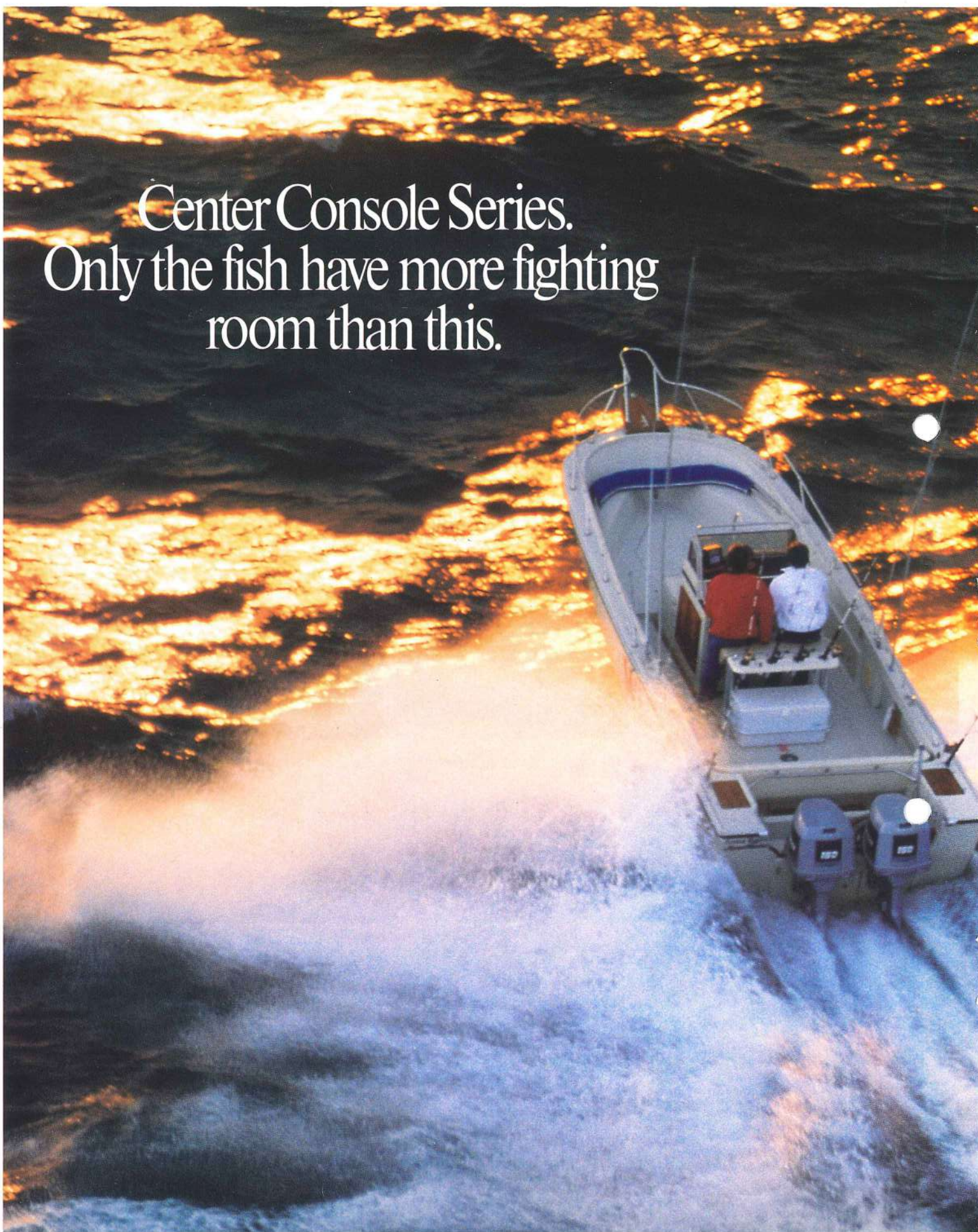

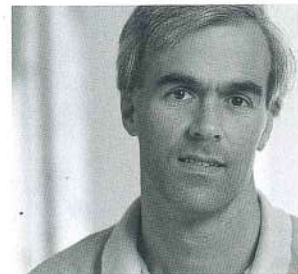
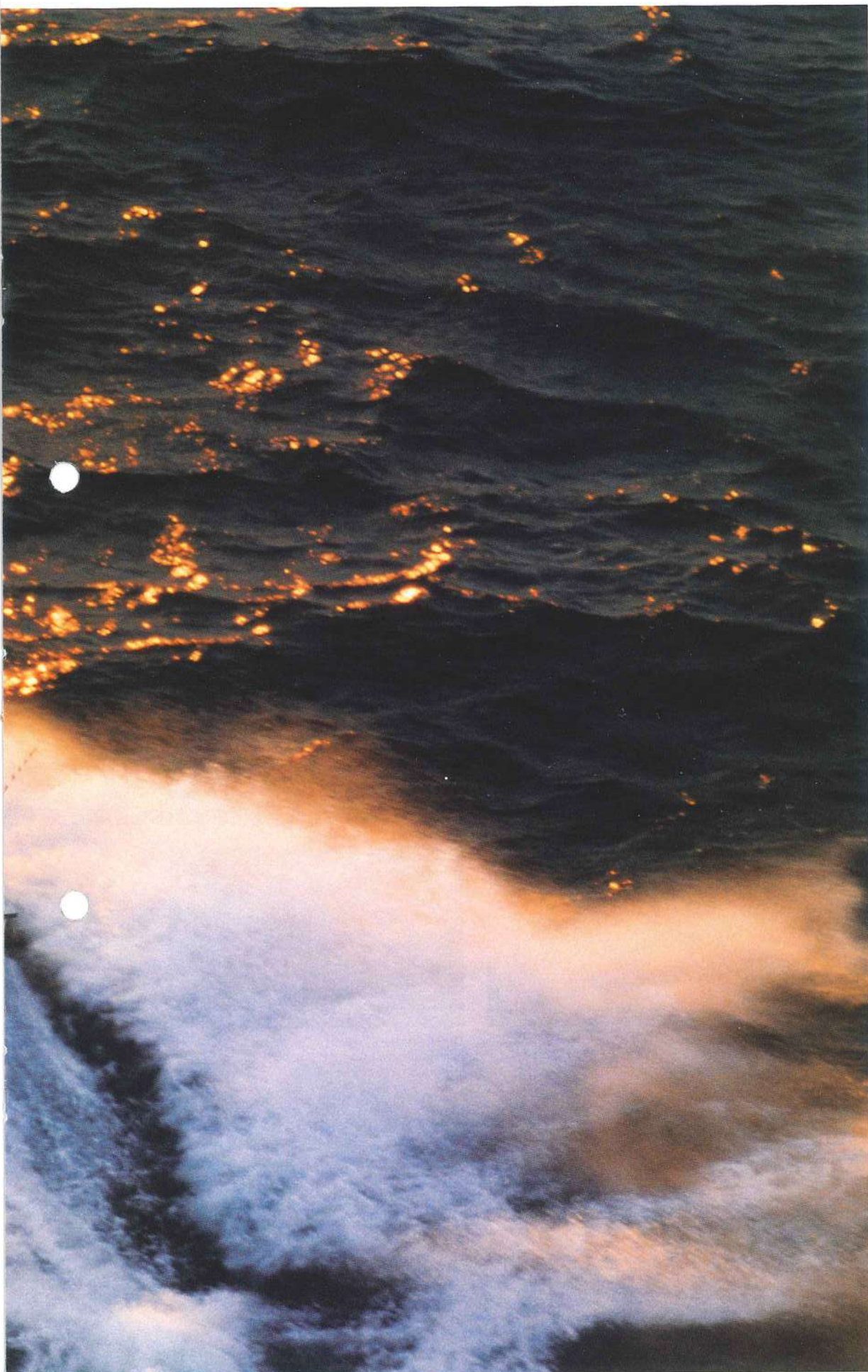

“I have friends who own boats a lot bigger than my Whaler. But you know what? When the weather gets rough, they come fishing in my Whaler.”



Montauk is just as comfortable onshore as it is offshore.



The Montauk's center console leaves more than enough room to get around.



The Montauk is so stable, it can go almost anywhere a big sportsfisherman can.

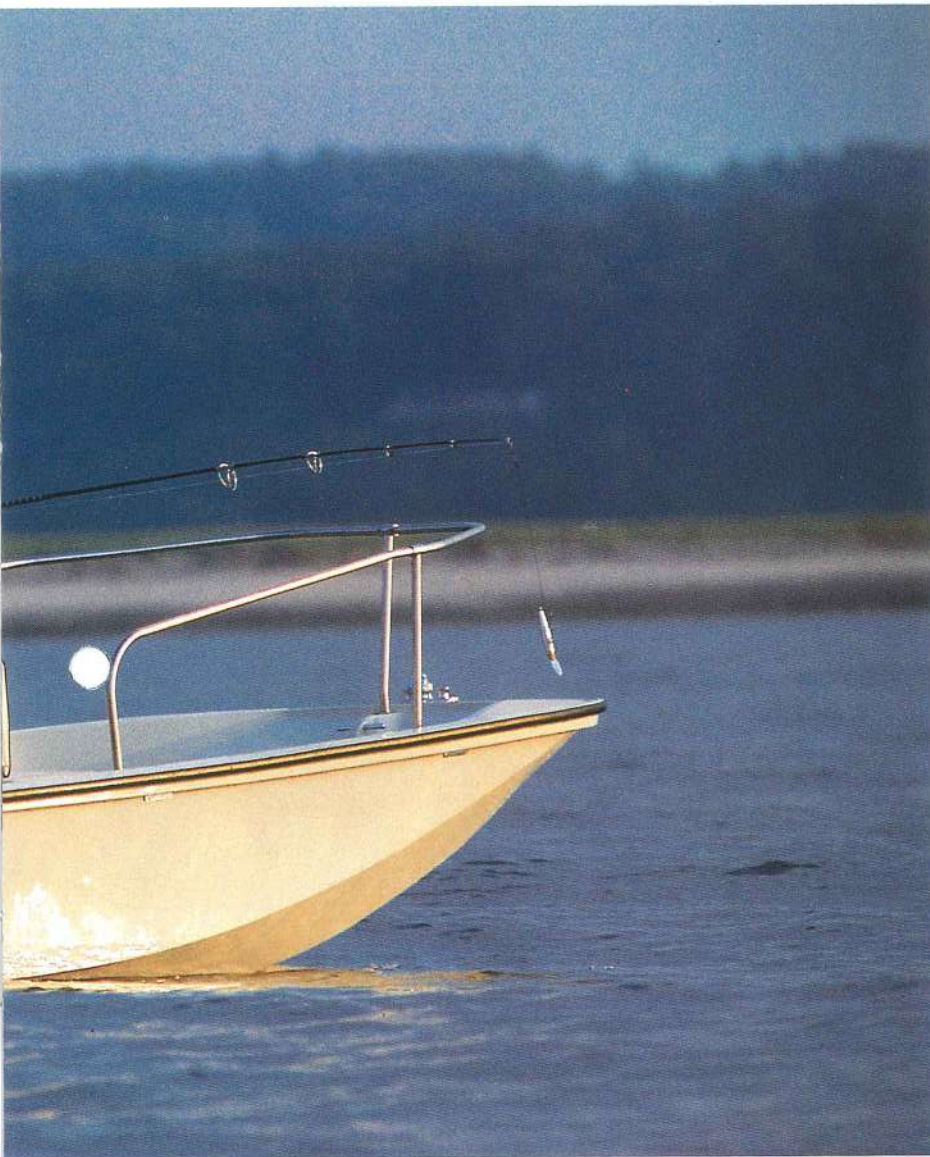

**L**et's talk Montauk. The boat that pioneered the center console revolution. The boat whose name is synonymous with bending poles and screeching reels. The boat that's inspired more than a few anglers to trade in far bigger boats for Montauk performance.

To what does the Montauk owe such fame? For one thing, it's a Boston Whaler. Which means the Montauk is ruggedly built, unsinkable and stable enough to venture where even big sportsfishermen tread.

For another thing, the Montauk is the original center console fishing machine. The first to maximize your fish-fighting room by minimizing the space taken up by controls.

Whaler performance and reliability combined with Whaler innovation. Montauk was bound to become a classic, and it did.

## Montauk

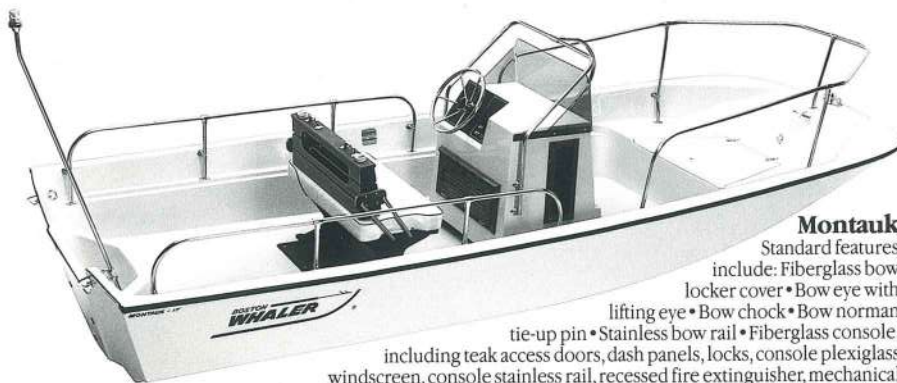

**Montauk**  
Standard features include: Fiberglass bow locker cover • Bow eye with lifting eye • Bow chock • Bow norman tie-up pin • Stainless bow rail • Fiberglass console, including teak access doors, dash panels, locks, console plexiglass windscreen, console stainless rail, recessed fire extinguisher, mechanical steering with stainless wheel, switch panel with 2 pre-wired accessory switches, fuses and bus bar • Reversible pilot seat • Stainless side rails • Heavy-duty rub rail • International navigation lights • Battery box kit • Drain plug • Pair of ski-lifting eyes.



The Outrage 17's deep-Vee hull slices cleanly through the waves.



When you fish offshore, you need a stable boat. Outrage 17.



The Outrage 17 gets you out to your favorite fishing spot safely and quickly.





**T**here is one boat that measures up to the Montauk's legacy. It's called Outrage.<sup>®</sup> A center-console, deep-Vee tough enough to get you where the big fish live, dependable enough to get you back.

Our Outrage 17, for example. The smallest of the Outrage family, it lets you enjoy deep-Vee performance without digging deep into your bank account. But don't let its dimensions deceive you. The 17 can slug it out alongside boats twice its size, then beat them back to the breakwater, all on less fuel than a sportfisherman consumes idling at the dock.

Like every Outrage, the 17 is also big on possibilities. You can add all the gear and instrumentation you'll ever want or need, then look forward to fishing experiences that are second to none.

The Outrage 17. Small in stature, big on performance.

## Outrage 17

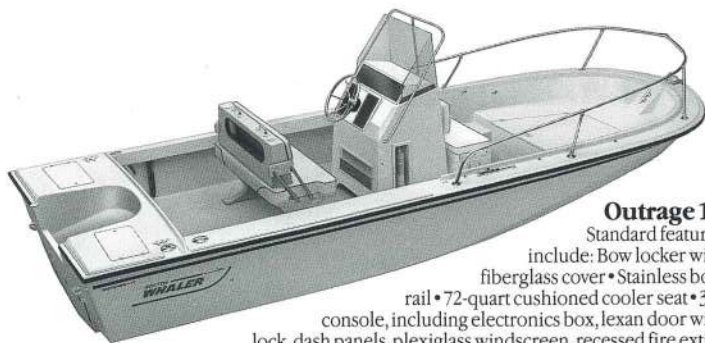

### Outrage 17

Standard features include: Bow locker with fiberglass cover • Stainless bow rail • 72-quart cushioned cooler seat • 30" console, including electronics box, lexan door with lock, dash panels, plexiglass windscreen, recessed fire extinguisher, storage bin, stainless steering wheel, switch panel with 2 pre-wired accessory switches, fuses and bus bar, stainless rail and single-cable steering • Fiberglass reversible pilot seat • Rod racks • Pair of flush mount rod holders • Cushioned console rod holders (6 rods) • Fiberglass gun'l boards • Stern deck with VRO and battery box storage • Heavy duty rub rail • Bow and stern u-bolt lifting eyes • 8" bow cleat • Marinium chocks • International navigation lights • 30-gallon fuel tank • Battery box kit.



On the run, the Outrage 19 tracks straight and true.



Get forward quickly and easily aboard the Outrage 19.



The 19's deep-Vee hull is ready to run whenever you're ready to fish.



**W**hat strikes envy in the hearts of fishermen everywhere? The sight of an Outrage 19 making for home with the whole day's catch aboard and one great story to tell.

It's a story that's been told time and time again. Of lines drawn tight, poles bent high, and buckets overflowing with glittering trophies. All made possible by a center console that gives you complete and unobstructed 360-degree fishability. A smooth-tracking deep-Vee hull powered by up to a 150-horsepower engine. And the kind of solid, one-piece construction that lets you deal swiftly and surely with any offshore obstacle that gets in your way.

The Outrage 19. It's fiercely rugged, incredibly stable, and absolutely unsinkable. Take one out and you're sure to bring back a few stories of your own to tell.

## Outrage 19

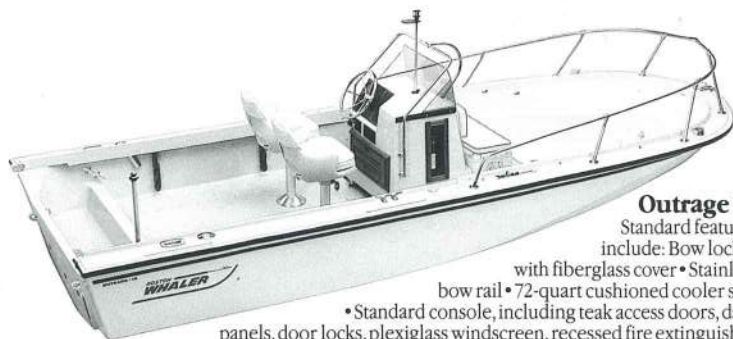

### Outrage 19

Standard features include: Bow locker with fiberglass cover • Stainless bow rail • 72-quart cushioned cooler seat • Standard console, including teak access doors, dash panels, door locks, plexiglass windscreen, recessed fire extinguisher, stainless steering wheel, switch panel with 2 pre-wired accessory switches, fuses and bus bar, stainless rail and twin-cable steering • Two swivel seats • Rod racks • Pair of flush mount rod holders • Cushioned console rod holders (6 rods) • Springline cleats • Fiberglass gun'l boards • Heavy-duty rub rail • Recessed aft cleats with hawsepipe • International navigation lights • 63-gallon fuel tank • Battery box kit • Lifting eyes.



The Outrage 22 was made to travel where the big fish live.



The Outrage 22. It's earned the respect of sportsfishermen twice its size.

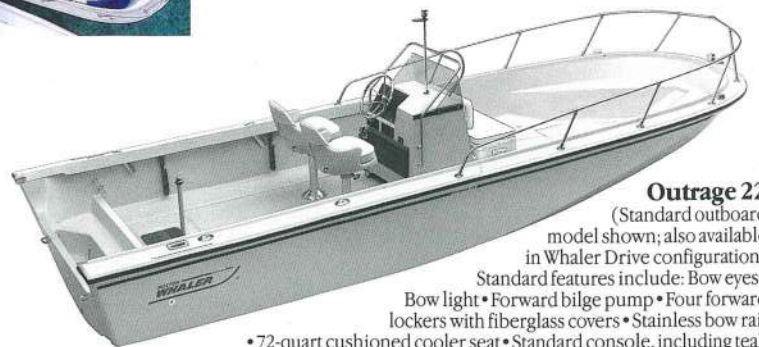

### Outrage 22

(Standard outboard model shown; also available in Whaler Drive configuration)

- Standard features include: Bow eyes • Bow light • Forward bilge pump • Four forward lockers with fiberglass covers • Stainless bow rail • 72-quart cushioned cooler seat • Standard console, including teak access doors, dash panels, door locks, plexiglass windscreen, stainless rail, recessed fire extinguisher, stainless steering wheel, switch panel with 2 pre-wired accessory switches, fuses and bus bar, and hydraulic steering • Two swivel seats • Under gun'l rod racks • Four flush-mount rod holders • Cushioned console rod holders (6 rods) • Springline cleats • Fiberglass gun'l boards • Heavy-duty rub rail • Recessed aft cleats with hawsepipe • International navigation lights • 77-gallon fuel tank • Battery box kit • Aft fishwell with teak cover • Aft quarter cleats • Aft baitwell with aerating pump • Stern deck with 15-gallon removable fishbox (Whaler Drive model) • Lifting eyes.



**W**e dedicated the Outrage 22 and 25 to all those for whom the pursuit of happiness is tied to the pursuit of fish. Each is ready to run whenever you are. Wide open, their hulls tear through the water like bluefish, providing a smooth, dry, unbelievably comfortable ride. And because they're Whalers, the 22 and 25 are built not to sink.

Of course, how well they perform below the waterline is only half the story. On deck, the 22 and 25 are uncluttered and spacious, so you won't have to trip and stumble to get fore and aft. Whaler Drive® models free up even more deck space by allowing you to mount the engines further aft. They also provide two feet of extra running surface for an even smoother trip through the water.

The Outrage 22 and Outrage 25. Pack up your gear, fire up the engines. The fish will never know what hit them.

## Outrage 22 and 25



The Outrage 25. What fishing dreams are made of.



Its wide-open cockpit gives you more than enough room to move around. Outrage 25.

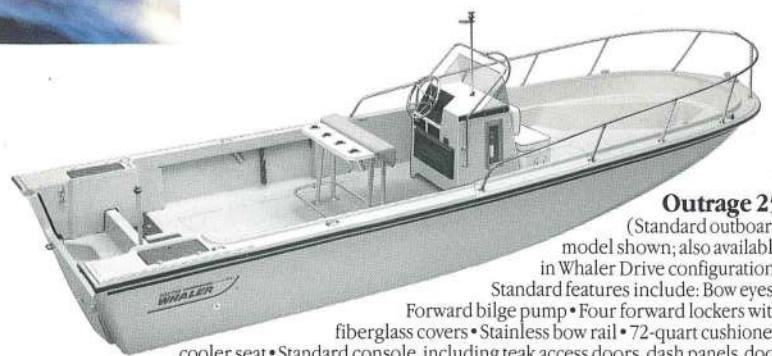

### Outrage 25

(Standard outboard model shown; also available in Whaler Drive configuration)

Standard features include: Bow eyes • Forward bilge pump • Four forward lockers with fiberglass covers • Stainless bow rail • 72-quart cushioned cooler seat • Standard console, including teak access doors, dash panels, door locks, plexiglass windscreen, stainless rail, recessed fire extinguisher, stainless steering wheel, switch panel with 2 pre-wired accessory switches, fuses and bus bar, and hydraulic steering • Under gun'l rod racks • Four flush-mount rod holders • Cushioned console rod holders (6 rods) • Padded leaning post with rod holders and 94-quart cooler holder • Springline cleats • Fiberglass gun'l boards • Heavy-duty rub rail • Aft quarter boxes (port & starboard) • Aft baitwell with aerating pump • Aft cleats • International navigation lights • 140-gallon fuel tank • Battery box kit • Stern deck with 15-gal. removable fishwell (Whaler Drive model) • Lifting eyes.



Left: Each Cuddy has a 7-foot V-berth that sleeps two comfortably.

Right: Our Outrage Cuddies let you make short work of the farthest horizon.

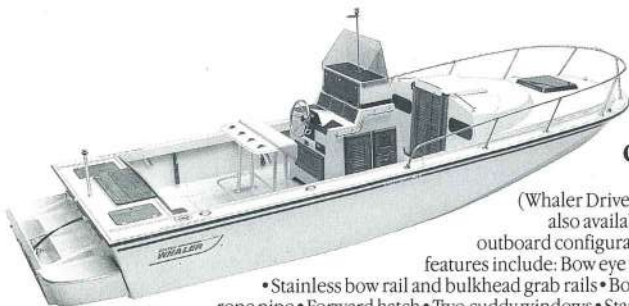

### Outrage 22 Cuddy

(Whaler Drive model shown; also available in standard outboard configuration)

Standard features include: Bow eye with lifting eye • Stainless bow rail and bulkhead grab rails • Bow deck anchor rope pipe • Forward hatch • Two cuddy windows • Standard console, including teak access doors, recessed fire extinguisher, console rod holders (6 rods), dash panels, door locks, stainless steering wheel, plexiglass windscreen, stainless rail, switch panel with 2 pre-wired accessory switches, fuses and bus bar, and hydraulic steering • Two swivel seats • Two cabin lights • Bunk cushions • Four flush-mounted rod holders • Fiberglass gun'l boards • Baitwell with aerating pump • Stern deck with 15-gal. removable fishwell (Whaler Drive model) • Heavy-duty rub rail • International navigation lights • Recessed aft cleats with hawsepipes • 77-gallon fuel tank • Bilge pump with automatic control switch • Battery box kit. (Shown with optional Super Console and leaning post)

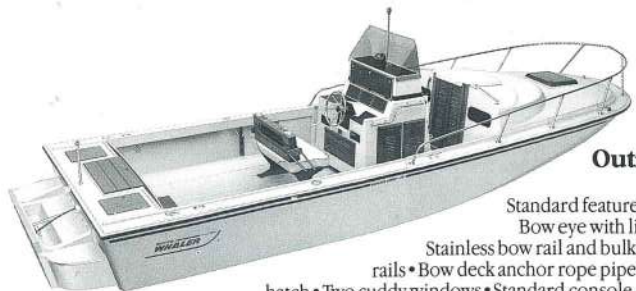

### Outrage 25 Cuddy

Standard features include:

Bow eye with lifting eye • Stainless bow rail and bulkhead grab rails • Bow deck anchor rope pipe • Forward hatch • Two cuddy windows • Standard console, including teak access doors, recessed fire extinguisher, console rod holders (6 rods), dash panels, door locks, stainless steering wheel, plexiglass windscreen, stainless rail, switch panel with 2 pre-wired accessory switches, fuses and bus bar, and hydraulic steering • Padded leaning post with aft rocket launchers and 94-quart cooler holder • Two cabin lights • Bunk cushions • Four flush-mounted rod holders • Springline cleats • Fiberglass gun'l boards • Aft baitwell with aerating pump • Stern deck with 15-gal. removable fishwell • Heavy-duty rub rail • International navigation lights • Recessed aft cleats with hawsepipes • 140-gallon fuel tank • Bilge pump with automatic control switch • Battery box kit. (Shown with optional reversible pilot seat and Super Console)



**L**ike every Outrage, our Cuddies are built for catching fish. The only difference is, they're also built for catching a rest.

The 22, 25 and 27 each boast a forward V-berth large enough to sleep two adults; spacious enough to stow all your gear out of the way. There's privacy for a head, and security for your equipment when you're away from the boat. Solid teak companionway doors open on these interiors, and liftable forward Lexan hatches provide ample light and ventilation.

Of course, all this is not to say our Cuddies sacrifice one bit in the way of Outrage performance. Center-console battlestations maximize your fish-fighting room. Powerful deep-Vee hulls slice up the sea. And unsinkable Boston Whaler construction means you can feel safe wherever you go.

The Outrage 22, 25 and 27 Cuddies. For when the fishing's too good not to spend the night.

## Outrage Cuddy



Left: The Outrage 27 Cuddy not only gives you a place to fish, it also gives you a place to sleep.

Right: Offshore obstacles are no match for the Outrage 27 Cuddy's powerful deep-Vee hull.



### Outrage 27 Cuddy

(Whaler Drive model shown; also available in standard outboard configuration)

Standard features include: Stainless bow rail • Fiberglass bow pulpit with rail • Bomar foredeck hatch • Anchor locker with hold-open hatch • Teak ladder for foredeck access • 35"-wide Super Console, including teak access doors, aluminum-framed safety-glass windshield, console rail, recessed fire extinguisher and twin-cylinder hydraulic steering with 18" stainless wheel • Padded leaning post • Cockpit coaming pads • Cockpit fish boxes • 10" springline cleats • Four flush-mounted rod holders • Under gun'l rod storage • Stern deck hawsepipes • Lift-out aft live well with raw water fill and recirculation, and two quarter storage boxes (Whaler Drive model) • Fold-down splashwell bulkhead (outboard model) • 12-volt cabin lights • Twin V-berths • Below-berth storage • Ten 7' cabin rod holders • International navigation lights • Battery selector switch • Two bilge pumps • 170-gallon fuel tank.

Sportfishing Series.  
Turn a day of fishing into  
an overnight success.

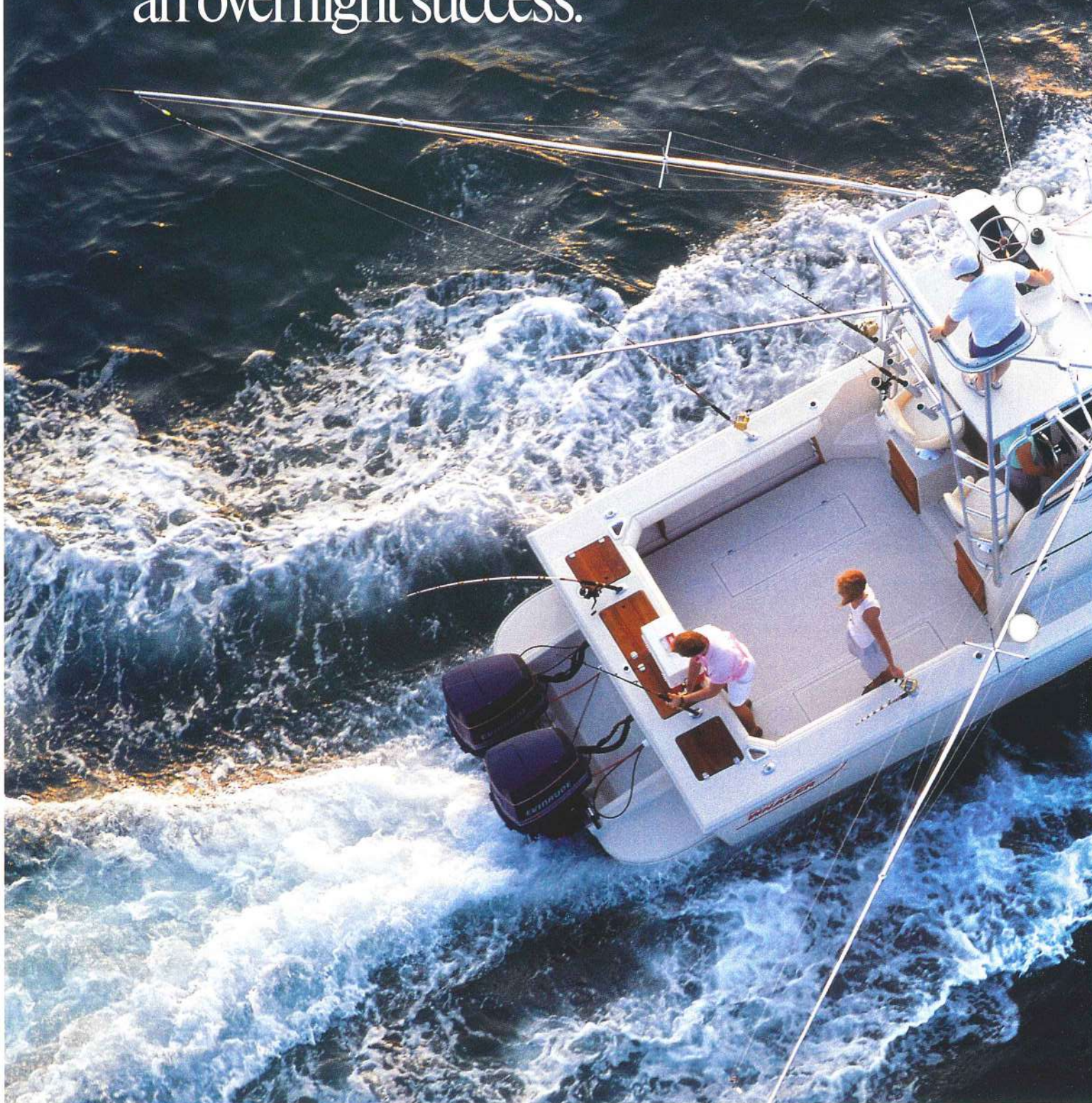



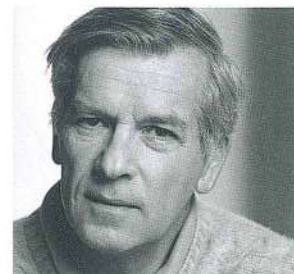

“I spent a year comparing fishing boats before deciding on my Whaler. The funny thing is, it was one of the first boats I looked at, and I just kept coming back to it.”



The Revenge 22 has a deep-Vee hull, for a smooth, comfortable ride.



Two seven-foot bunks make the Revenge 22 a comfortable place to spend the night.

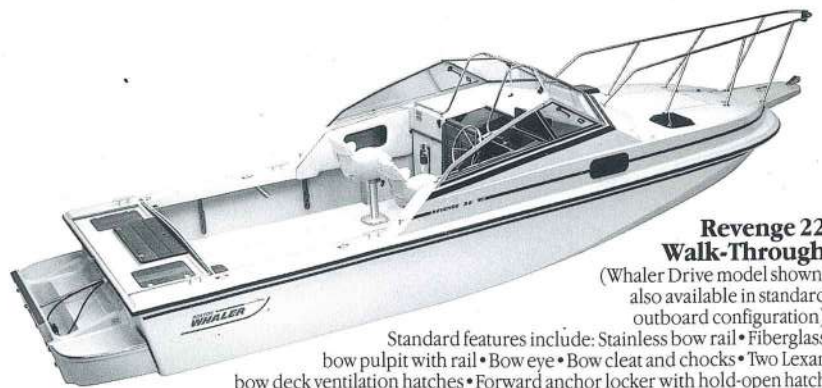

### Revenge 22 Walk-Through

(Whaler Drive model shown; also available in standard outboard configuration)

Standard features include: Stainless bow rail • Fiberglass bow pulpit with rail • Bow eye • Bow cleat and chocks • Two Lexan bow deck ventilation hatches • Forward anchor locker with hold-open hatch • Anodized aluminum walkthrough windshield • Slide-away walkthrough ladder • Upholstered cockpit panels with storage • Stainless cockpit grab rails • Two swivel seats • Plexiglass sunscreen (instrument panel) • Stainless wheel • Hydraulic steering • Switch panel with two pre-wired accessory switches, fuses and bus bar • Louvered companion-way doors • Door locks • Two seven-foot bunks • Two portholes with screens • Cabin cushion set • Fire extinguisher • Three forward storage lockers under V-berths • Aft fishwell with teak cover • Recessed aft cleats with hawsepipes • Under gun'l rod racks • Four flush-mounted rod holders • Aft baitwell with aerating pump • Stern deck with 15 gal. removable fishwell (Whaler Drive model) • Springline cleats • Heavy-duty rub rail • Bilge pump with automatic control switch • Battery box kit • 77-gallon fuel tank.

**W**hen boats go by the not-so-modest name of Revenge<sup>®</sup>, you'd expect them to be solid, powerful and worthy of the most rugged offshore environs.

What you can also expect are interiors that offer shelter when it gets rough outside and privacy when it gets dark. Handsome teak joinery accents the seven-foot V-berths, while double Lexan hatches and ports afford plenty of light and ventilation.

On deck, the Revenge 22 and Revenge 25 are just as accommodating. Each features a walk-through windshield that opens onto an extended, full-length bow pulpit. Which lets you get fore and aft just as easily as the fish. And each offers cushioned swivel seats, under-gunnel rod racks, an aft fishwell, baitwell and more.

The Revenge 22 and the Revenge 25. Fishing boats that also go by the not-so-modest name of Boston Whaler.

## Revenge



The Revenge 25's walk-through windshield and extended bow pulpit afford easy access to the bow.



Belowdecks, plenty of light and ventilation add to the Revenge 25's roominess and comfort.

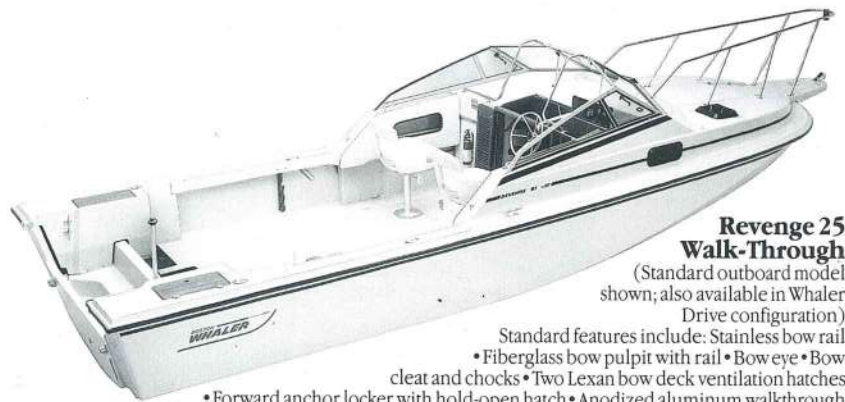

### Revenge 25 Walk-Through

(Standard outboard model shown; also available in Whaler Drive configuration)

- Standard features include: Stainless bow rail • Fiberglass bow pulpit with rail • Boweye • Bow cleat and chocks • Two Lexan bow deck ventilation hatches • Forward anchor locker with hold-open hatch • Anodized aluminum walkthrough windshield • Slide-away walkthrough ladder • Upholstered cockpit panels with storage • Stainless cockpit and companionway grab rails • Two swivel seats • Plexiglass sunscreen (instrument panel) • Stainless wheel • Hydraulic steering • Switch panel with two pre-wired accessory switches, fuses and bus bar • Louvered companionway doors • Door locks • Two seven-foot bunks • Two portholes with screens • Cabin cushion set • Fire extinguisher • Three forward storage lockers under V-berths • Aft fishwell with teak cover • Recessed aft cleats with hawsepipes • Under gun'l rod racks • Four flush-mounted rod holders • Aft baitwell with aerating pump • Stern deck with 15 gal. removable fishwell (Whaler Drive model) • Springline cleats • Heavy-duty rub rail • Bilge pump with automatic control switch • Battery box kit • 140-gallon fuel tank.



The 25's interior features a fold-down dinette and secure storage for your rods and equipment.



The 25's hull shape deflects spray out, back and away for a dry, comfortable ride.



The 25's spacious cockpit lets you mount a fighting chair, and still have plenty of fighting room.

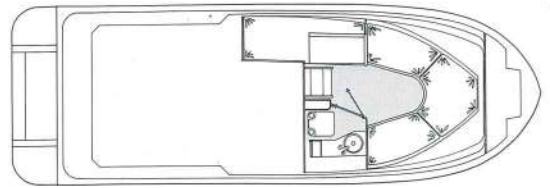
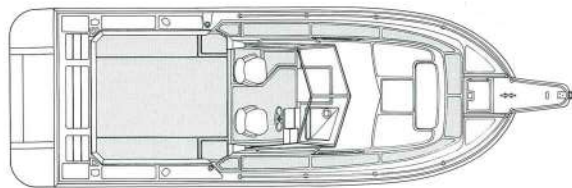

### Whaler 25 Walkaround

**Standard Equipment—Hull, Deck and Cockpit Group:** Bow pulpit with stainless bow rail, cushioned forward seat, docking lights, anchor locker and roller, cushioned pedestal seats with tackle drawers below, hydraulic steering, hydraulic trim tabs, compass, automatic bilge pumps (2), coaming bolsters, insulated fish boxes (2) with outboard drain, aft livewell with raw water fill and recirculation (lift-out), quarter storage boxes (2), insulated coolers (2), horizontal rod racks, flush mount rod holders (4), washdown pump with hose, self-bailing 50 sq. ft. cockpit, 250 gallon fuel tank. **Cabin Group:** Lighted V-berth and quarter berth, cushions, under bunk storage, dinette, fold-down galley counter, rod storage, fully enclosed and lighted head, sink with pressure system, 15 gallon water tank, head with deck pump out/overboard, vanity with overhead cabinet.



If you're considering a sportfishing boat, these two wide beam Whalers should help narrow down your options. Compare them with anything else in their class and you'll see what we mean.

Few sportsfishermen in the 25- to 30-foot range offer this much fighting room, for example. On the run, few track as smoothly. And none handle rough weather with such unsinkable confidence. As if that wasn't enough, the 25 and 27 offer easy walkaround access to the bow when your fish decides to go forward.

Belowdecks, the 25 and 27 keep on shining. With cabins that include full galleys, dinettes and private head compartments, you'll be tempted to turn every fishing trip into an overnight success.

The Whaler®25 and Whaler 27 Walkaround. Once you make the comparison, you'll make the decision – Boston Whaler.

## Whaler Walkaround



Who says you have to sacrifice creature comforts for great fishability?



The wide walkaround area surrounding the cabin lets you follow your fish around the boat easily.



The Whaler 27 Walkaround. It towers above everything else in its class.

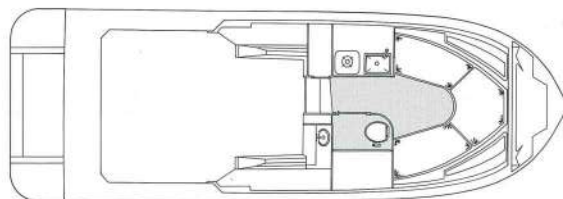
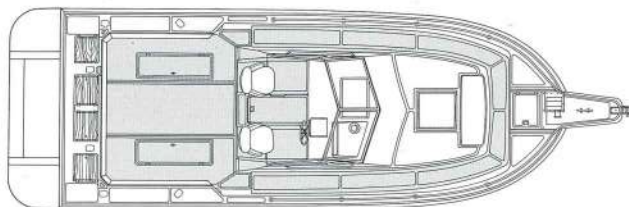

### Whaler 27 Walkaround

**Standard Equipment – Hull, Deck and Cockpit Group:** Bow pulpit with stainless bow rail, cushioned forward seat, docking lights, anchor locker and roller, cushioned pedestal seats with tackle drawers/storage below, hydraulic steering, hydraulic trim tabs, compass, automatic bilge pumps (2), coaming bolsters, insulated fish boxes (2) with outboard drain, aft livewell with raw water fill and recirculation (lift-out), quarter storage boxes (2), horizontal rod racks, flush mount rod holders (4), washdown pump with hose, self-bailing 50 sq. ft. cockpit, 270 gallon fuel tank. **Cabin Group:** Lighted V-berth, cushions, under bunk storage, dinette, hanging locker, shore power with 110-volt battery charger, hot water heater (4 gal.), galley with sink, electric/alcohol stove, refrigerator and storage, rod storage, fully enclosed and lighted head, sink with pressure system, 28 gallon water tank, shower, manual marine head with holding tank, macerator and pump out, vanity with overhead cabinet.



The 27 Full Cabin offers 6'2" of headroom, an enclosed head and full galley complete with icebox and sink.



Sometimes you have to head 30 miles out to bring the big fish in. 27 Full Cabin.

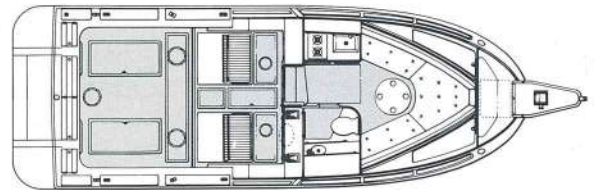

### Whaler 27 Full Cabin

**Standard Equipment – Cabin/Comfort Group:** 12-volt cabin lights, fiberglass galley unit with 3 drawers, cup and dish rack, sink, and ice box, enclosed marine head with holding tank and dockside/overboard pumpout capability (electric), fiberglass vanity unit with sink and storage, fiberglass storage cabinet at eye-level with mirrored sliding doors, twin vee-berths and cushions, below-berth storage, hanging locker, dinette table with drink holders (4), back rest cushions, cabin headliner, cabin side windows, fresh water system with 30 gallon tank.  
**Boat/Cockpit Group:** Sliding pilot seat and companion seat, International rule navigation lights, 10' springline cleats, stern deck hawsepipes, anchor locker with hold-open hatch, stainless steel bow rail, three-section ventilating windshield, Bomar foredeck hatch, 18" stainless steel steering wheel, plexiglass instrument panel hood, forward storage pads, horn, dual wipers, cockpit courtesy lights, fuel capacity 170 gallons, battery selection switch, bilge pumps, fire extinguisher, hydraulic steering (twin cylinder), factory shrink wrap for shipment, fiberglass bow pulpit w/stainless steel rail, hydraulic trim tabs, quarter storage boxes (2).  
**Fishing Group:** Flush-mount rod holders (2), aft livewell with raw water fill and recirculation (lift-out), under gun 1 rod storage.



For a company that started out building small boats, we've taken some pretty big strides in our history. But none so big as the Whaler 27 Full Cabin and the Whaler 31.

Both are foam cored, deep-Vee'd and wide of beam. Which means the 27 Full Cabin and Whaler 31 are not only unsinkable, but tough enough to take you just about anywhere.

A 245-gallon fuel tank helps the 31 log many offshore miles. While its mighty 125-square-foot cockpit lets you deal just as efficiently with anything that swims.

Down below, each comes complete with running water, a private head compartment and a full galley. The 31 has a forward stateroom as well as a fold-down dinette, so it sleeps four comfortably, while the 27 Full Cabin easily accommodates two.

The 27 Full Cabin and the Whaler 31. The biggest Boston Whalers yet.

## Whaler 27 Full Cabin and Whaler 31



You'll find a complete galley aboard the Whaler 31, with refrigerator and alcohol/electric stove.



The 31 has a fold-down dinette that offers additional sleeping space for two.



Big and powerful, the 31 can take you offshore with confidence.

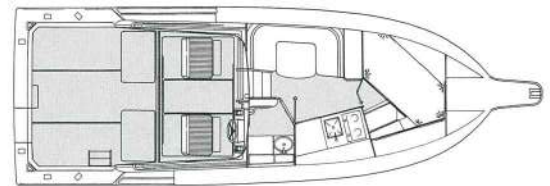

### Whaler 31

**Standard Equipment—Instrumentation, Equipment & Safety:** Interior lighting, cockpit courtesy lights, engine room light, circuit breaker switch panel, dual battery boxes and switches, battery charger, shore power—two 30 amp circuits, hydraulic steering system, twin engine controls, raw water intake strainers, mufflers, rudders and struts, stainless engine shafts (1/2"), 245 gallon fuel tank, propellers (gas: 18" x 20", diesel: 20" x 23"), tachometers, voltmeters, temperature gauges, oil pressure gauges, hour meters, compass (4"), bilge pumps, bilge blowers, windshield wipers, dual electric horns, fire extinguishers—halon below (gas only), high water bilge alarm, engine room insulation, anchor and chain, engine alarm system (overheat), fuel filter, scuppers with flaps, self-aligning stuffing box, transmissions: Borg Warner velvet drive (gas), MPM (diesel), underwater hardware elec. bonded, water tank with pressure system (40 gal.), fuel tank valves, freshwater cooling, raw water flow alarm, fume detector, engine room (gas only), carbon monoxide alarm, engine alarm, oil pressure alarm, engine priming (diesel only). **Hull, Deck and Cockpit:** Sliding helm seats (2), cockpit bolsters, recessed trim tabs, bow pulpit with rail and anchor roller, in-deck fish boxes, mooring cleats, spring, bow and stern cleats, forward anchor locker, bow rail, stainless rub rail, mahogany rod racks (cockpit), cockpit boarding ladder, rod holders (4), saltwater washdown, fire extinguishers (2), transom steps. **Comfort and Interior:** *Cabin:* carpet, drapes, screens, fire extinguisher. *Galley:* sink with hot and cold water pressure system, AC/DC refrigerator, convertible dinette table, filler cushion, galley storage, alcohol/electric 110 volt stove, hanging locker. *Stateroom:* vanity, privacy door, double berth with matching pillows, hanging locker. *Head:* sink, shower, shower sump/bilge pump, full-length mirror, vanity/medicine cabinet, electric head with holding tank, dockside water connection, hot water heater, accessories (paper hanger, towel bar, towel ring).

Sport Series	L.O.A. (1)	Beam	Draft (2)	Boat weight (lbs.) standard model (1)	Max. wt. capacity (persons, motor & gear) (3)	Swamped capacity (4)	Persons capacity	Max. H.P. (5)	Min. H.P. (6)	Recommended engine shaft length	Standard fuel capacity (gal.)
Tender 9	9'0"	4'6"	5"	165	405	600	3	5	-	15"	-
Tender 11	11'4"	5'0"	6"	210	560	750	3	10	-	15"	-
Sport 13	13'4"	5'5"	6"	360	1200	1600	6	40	9	20"	-
Sport 15	15'3"	5'8"	8"	580	1055	1800	5	70	20	20"	-
Super Sport 11	11'4"	5'0"	6"	250	560	750	3	20	-	15"	-
Super Sport 13	13'4"	5'5"	6"	360	1200	1600	6	40	9	20"	-
Super Sport 15	15'3"	5'8"	8"	580	1055	1800	5	70	20	20"	-
Sport GLS 13	13'4"	5'5"	6"	360	1200	1600	6	40	9	20"	-
Sport GLS 15	15'3"	5'8"	8"	580	1055	1800	5	70	20	20"	-
Sport GLS 17	16'7"	6'2"	9"	850	1415	2000	7	100	35	20"	-
Super Sport Limited 15	15'3"	5'8"	8"	630	1055	1800	5	70	20	20"	-
Super Sport Limited 17	16'7"	6'2"	9"	900	1415	2000	7	100	35	20"	-
Newport	16'7"	6'2"	9"	950	1415	2000	7	100	35	20"	-
Mischief	15'3"	5'8"	8"	630	1055	1800	5	70	20	20"	-

### Center Console Series

Montauk	16'7"	6'2"	9"	900	1415	2000	7	100	35	20"	-
Outrage 17	17'3"	6'8"	13"	1020	1340	1850	6	120	50	20"	29
Outrage 19	18'6"	7'2"	10"	1250	1925	3000	7	150	75	25" <sup>(7)</sup>	63
Outrage 22 outboard	22'3"	7'5"	14"	2050	2655	5000	11	240	90	25" <sup>(7)</sup>	77
Outrage 22 Whaler Drive	24'2"	7'5"	14"	2300	2655	5000	11	300	90	25" <sup>(7)</sup>	77
Outrage 25 outboard	24'7"	8'0"	16"	3300	3035	9000	12	300	115	25" <sup>(7)</sup>	140
Outrage 25 Whaler Drive	26'6"	8'0"	16"	3550	3035	9000	12	450	115	25" <sup>(7)</sup>	140
Outrage 22 Cuddy O.B.	22'3"	7'5"	14"	2250	2655	5000	11	240	90	25" <sup>(7)</sup>	77
Outrage 22 Cuddy WD	24'2"	7'5"	14"	2500	2655	5000	11	300	90	25" <sup>(7)</sup>	77
Outrage 25 Cuddy WD	26'6"	8'0"	16"	3750	3035	9000	12	450	115	25" <sup>(7)</sup>	140
Outrage 27 Cuddy O.B.	26'7"	10'0"	21"	4130	4200	10000	12	600	300	25" <sup>(8)</sup>	170
Outrage 27 Cuddy WD	29'1"	10'0"	21"	4545	4200	10000	12	600	300	25" <sup>(8)</sup>	170

### Sportfishing Series

Revenge 22 W-T O.B.	22'3"	7'5"	14"	2350	2655	5000	11	240	90	25" <sup>(7)</sup>	77
Revenge 22 W-T WD	24'2"	7'5"	14"	2600	2655	5000	11	300	90	25" <sup>(7)</sup>	77
Revenge 25 W-T O.B.	24'7"	8'0"	16"	4000	3035	9000	12	300	115	25" <sup>(7)</sup>	140
Revenge 25 W-T WD	26'6"	8'0"	16"	4250	3035	9000	12	450	115	25" <sup>(7)</sup>	140
Whaler 25 Walkaround WD	27'11"	9'6"	18"	4600	4200	10000	12	550	300	25" <sup>(8)</sup>	250
Whaler 27 Walkaround WD	29'1"	10'0"	21"	5850	4200	10000	12	600	300	25" <sup>(8)</sup>	270
Whaler 27 Full Cabin WD	29'1"	10'0"	21"	5235	4200	10000	12	600	300	25" <sup>(8)</sup>	170
Whaler 31	31'9"	11'10"	38"	12900	4200	NA	12	-	-	-	245

(1) L.O.A. and boat weight include Whaler Drive unit on all Whaler Drive models. (2) Draft for outboard models with engine(s) tilted clear of water. May vary slightly depending on load and engine size. (3) BIA and U.S. Coast Guard Standards. Whaler 31' persons and gear only. (4) Total weight (persons, motor and gear) boat will support if filled with water. (5) V-8 engines are not compatible with standard 22'-27' Whaler Drive models. 27' Whaler Drive models will accept twin V-8 engines with the optional V-8 Whaler Drive. (6) Minimum horsepower to plane satisfactorily with light load. (7) 25" engine shaft for single installations and 20" engine shaft for dual installations (all Whaler Drive models require dual engines). (8) Requires dual engines with 25" shaft length.

株式会社マツイ

東京都港区麻布台2丁目4番7号  
TEL 03-586-4141



1149 Hingham Street, Rockland, MA 02370  
(617) 871-1400  
FAX (617) 872-7242  
Telex No. 940-0708

For the name and phone number of the dealer nearest you, call 1-800-WHALER9.

Specifications and standard equipment subject to change.  
Boston Whaler, Whaler Drive, Outrage, Revenge, Mischief™ and Whaler® are trademarks and registered trademarks of Boston Whaler, Incorporated.